

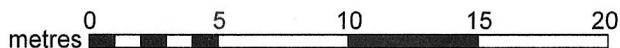

# ROSE GARDEN CAFE - WALL OFFSETS FROM VERTICAL

BlockNumber: 09  
 BuildingName: BUILDING I  
 BuildingRef: I  
 BlockGEA: 315.3  
 BlockGIA: 288.8  
 BlockNIA: 216.3

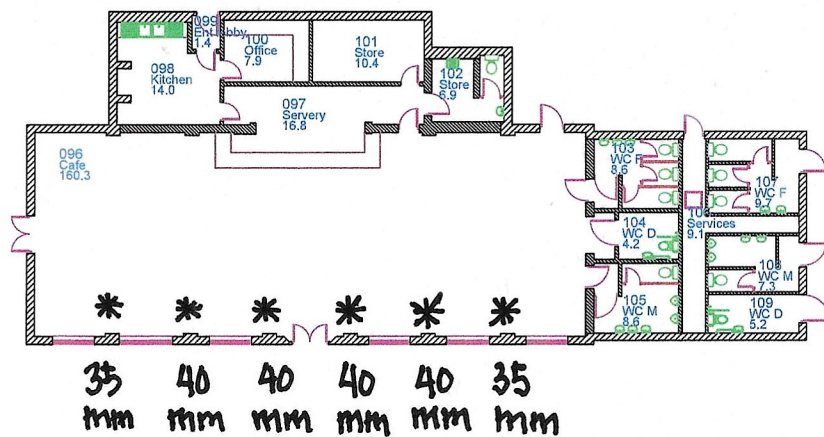

**NOTE:**  
 ESTIMATED MAXIMUM EXTERNAL OFFSET  
 GROUND LEVEL TO EAVES IS APPROX. 200mm

- NOTE:**
- OFFSETS MEASURED 1000mm ABOVE DADO.
  - NO ACCOUNT TAKEN FOR "CURVE" OF WALL.
  - ESTIMATED WALL OFFSET @ 3000mm AFFL ≈ 150mm (SEE ABOVE RE. "CURVE")

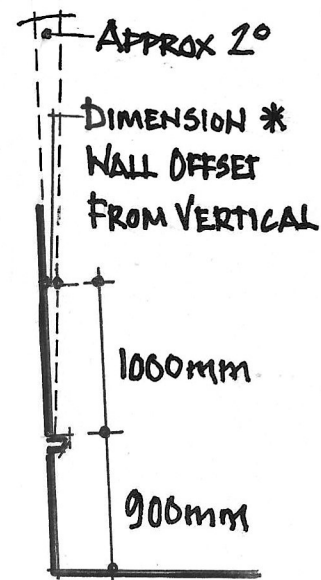
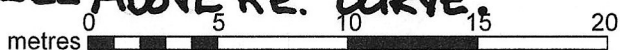
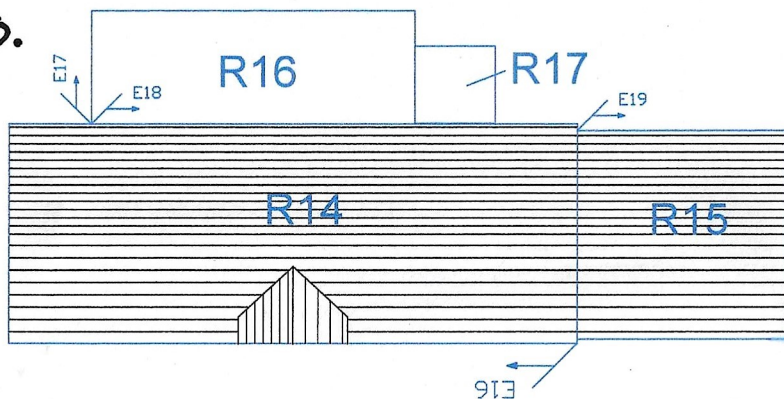

## OFFSETS MEASURED INT.

Rev	Date	Details	Drn	Chkd	Company
F	10/21	Drawing updated following site visit	DT	KM	SCC
E	05/18	Pavilion Toilets refurbished	JC	IMW	SCC
D	10/16	Drawing updated following site visit	DT	JC	SCC
C	06/14	Lodge Surveyed by CAD Capture	JC	DH	SCC
B	08/11	Net Areas Updated	JC	DJH	SCC
A	08/09	Drawing Conversion by JC	JC	DH	SCC

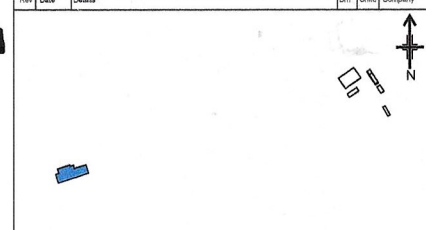

**Sheffield City Council**  
 Property Data Team  
 Level 3 East Wing  
 Moorfoot  
 Sheffield  
 S1 4PL  
 0114 2735621  
 CorporatePropertyStrategy@sheffield.gov.uk

ESTABLISHMENT  
**Graves Park**  
 TYPE  
**Park**  
 TITLE  
**BUILDING I**  
 ESTABLISHMENT REF.  
**EST00608**  
 SITE REF.  
**03190**

JB.10/01/23

KEY	NOTES	COPYRIGHT	DRAWN BY	SCALE	DATE	CHECKED
054 -ROOM NUMBER	Doorways symbols represent clear opening width. All floor measurements have been rounded down to the nearest 50mm.	Maps are reproduced from Ordnance Survey with permission of HMG. OS Licence No. 10001816. This drawing is protected by copyright. The Copyright owner is Sheffield City Council.	DT	1:200 @ A3	07/10/2021	KM
195 -ROOM AREA (sqm)			DRAWING No			REVISION
			8 of 15			F