

# Corporate Identity Standards

May 2011 . V3





# A fresher look for the Council

Design has a key role to play in improving our ability to communicate clearly. We have produced these standards to ensure conformity of style for all Sheffield City Council promotional material and printed products.

They are intended for use by our in-house designers, our contractors and to act as a reference for officers responsible for commissioning promotional material.

All work **must** comply with these guidelines.

It is important that Sheffield City Council communicates with 'One Voice'. The overall aim is to achieve a consistency of message and style of communication throughout our organisation. Given this, these standards are not optional. We trust we have your support in ensuring these standards are followed.

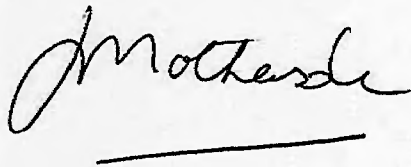

**John Mothersole, Chief Executive**

Contents	Page
<b>The Logo</b>	<b>2</b>
<b>Vehicles</b>	<b>5</b>
<b>Signage</b>	<b>6</b>
<b>The Typefaces</b>	<b>9</b>
<b>Press Advertising</b>	<b>13</b>
<b>Stationery</b>	<b>14</b>
<b>Templates</b>	<b>16</b>
<b>Joint Branding</b>	<b>18</b>
<b>Clothing</b>	<b>19</b>
<b>Name and Identity Cards</b>	<b>21</b>
<b>Awards</b>	<b>22</b>
<b>Useful Contacts</b>	<b>23</b>

## The Logo

There is only one Council logo, no other logos can be used to represent Sheffield City Council. It is essential that the logo is always used according to these standards.

The logo can be reproduced in a single colour, however it is important that the colour used is strong enough to be visible and the type legible against the background.

The logo must not be altered in any way from the original, in shape, proportions and typefaces.

The logo must not be used in conjunction with any type to form another logo.





# The Logo: Sizes

## Minimum size

The logo must never be reduced below 15mm in width. The width and height dimensions must always appear in proportion and should never be expanded, condensed or distorted.

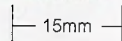

## Logo Size Matrix

JC Decaux Posters	200mm	Business Cards	23mm
A0 Posters	100mm	Letterheads	38mm
A1 Posters	50mm	Compliments slips	38mm
A2 Posters	40mm	Forms	15mm/25mm
A3 Posters*	35mm	Banner Stand	140mm
A4 Posters*/Brochures/ Leaflets	25mm	Pop up Display	140mm
A4 Report Cover*	25mm	Advertisement Borders - pre set template	
A5 Posters*/Brochures/ Leaflets	20mm	Vehicle Side Panel - Vehicle specific	
A6 Posters/Brochures/ Leaflets/Postcards	15mm	Building Sign - Sign Specific	
A7 Posters/Brochures/ Leaflets/Postcards	15mm	Powerpoint Presentation* - pre-set template	

# Positioning the Logo: Printed Material

When the logo appears on **printed material** representing the council, it should be positioned to the front face in the bottom right hand corner.

The exact position is dependent on the selected margin widths as illustrated.

This means that any printed or published material for example, posters, leaflets, brochures, booklets, reports, displays, exhibition, J.C. Decaux posters, postcards, advertising hoardings, will follow this standards.



JC Decaux Poster



A5 Booklet Cover

# Positioning the Logo: Vehicles

Council vehicles vary greatly in shape and size - however the following standard livery will be applied.

Selected vehicles may carry corporate messages by prior agreement with the Communications Service  
Tel: 0114 273 5538

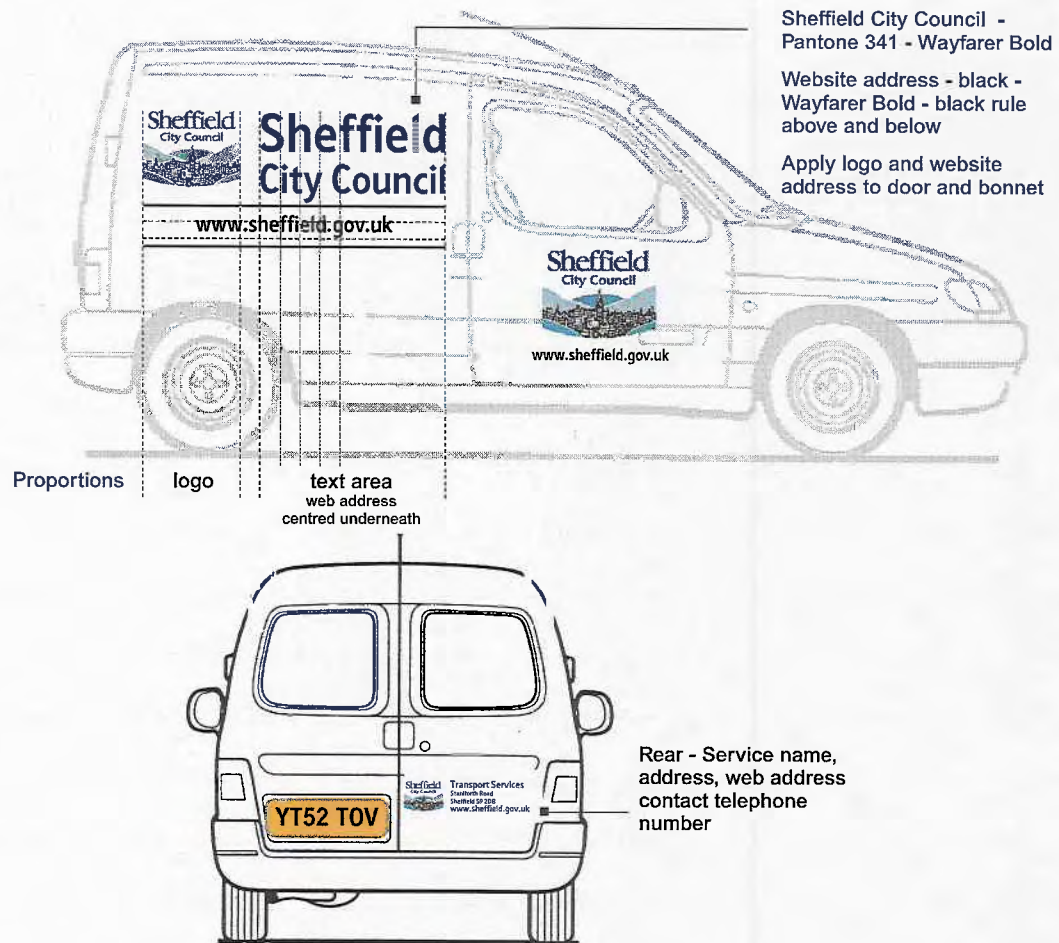



# Positioning the Logo: Signage

## Buildings

Buildings and fascias vary greatly in shape and size - however the following **standard graphics** will be applied.

Sign for premises with multiple council services in occupation will be signed as Sheffield City Council - internal directional signage will address specific service areas.



service block  
name/site name -  
Pantone 341 -  
Wayfarer Bold

website address -  
black - Wayfarer  
Bold - black rule  
above and below



## Park Signs

Park signs have been designed specifically to take into account Heritage Lottery funding.

Artwork is held with  
Communications Service  
Tel: 0114 273 5538

# Positioning the Logo: Signage

## Standard Scheme Boards

Separate guidance exists for Standard Scheme Sign Boards for the City. Creative Services hold templates for these and produce vinyls to order. For further information please contact the Communication Service - Tel: 273 5538

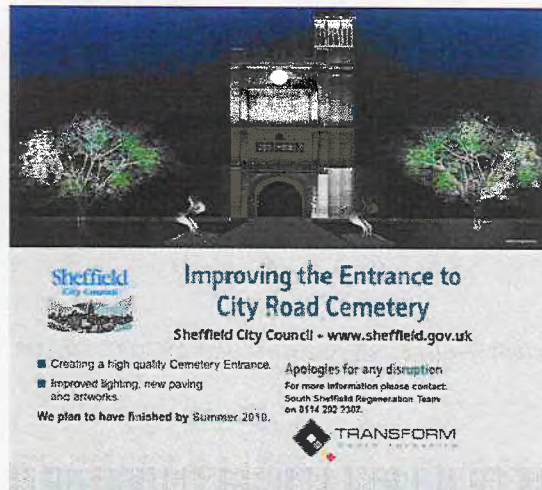

## Schools Signage

Schools should acknowledge the support of Sheffield City Council.



— student artwork

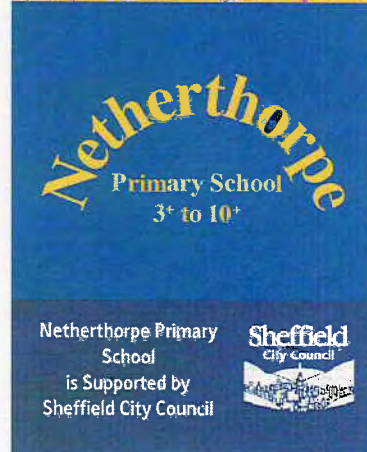

— School branding

— acknowledges SCC

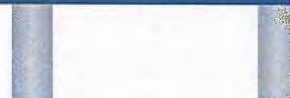



# Positioning the Logo: Signage

## Internal Signage

The implementation of Section 21 of the Disability Discrimination Act (DDA) means that we have a legal obligation to meet the needs of our blind and partially sighted staff and customers.

There is a need for a consistent approach to signage to ensure that identification and direction is provided in a uniform, easy to interpret format that is accessible to everyone and in particular addresses the needs of those who are visually impaired.

As a measure of good practice we should ensure that:

- All internal low level signage includes Braille and tactile information as specified by the RNIB.
- The sign panel, frame and text colours make it easy to read - maximum contrast.
- Signs use British Standard symbols
- Signs are colour co-ordinated to building interiors

For further information contact The Communication Service 273 5538.



This sign is for illustrative purpose and not an accurate braille representation

# Primary Typeface

The primary typeface for Sheffield City Council is Wayfarer - this will be used for headlining for example on vehicle liveries, signage, clothing and pre printed stationery.

## Wayfarer Light

abcdefghijklmnopqrstuvwxy  
 ABCDEFGHIJKLMNOPQRSTUVWXYZ  
 1234567890?!@£&;”

## Wayfarer Light Italic

*abcdefghijklmnopqrstuvwxy*  
*ABCDEFGHIJKLMNOPQRSTUVWXYZ*  
*1234567890?!@£&;”*

## Wayfarer Regular

abcdefghijklmnopqrstuvwxy  
 ABCDEFGHIJKLMNOPQRSTUVWXYZ  
 1234567890?!@£&;”

## Wayfarer Italic

*abcdefghijklmnopqrstuvwxy*  
*ABCDEFGHIJKLMNOPQRSTUVWXYZ*  
*1234567890?!@£&;”*

## Wayfarer Medium

abcdefghijklmnopqrstuvwxy  
 ABCDEFGHIJKLMNOPQRSTUVWXYZ  
 1234567890?!@£&;”

## Wayfarer Medium Italic

*abcdefghijklmnopqrstuvwxy*  
*ABCDEFGHIJKLMNOPQRSTUVWXYZ*  
*1234567890?!@£&;”*

## Wayfarer Semi Bold

abcdefghijklmnopqrstuvwxy  
 ABCDEFGHIJKLMNOPQRSTUVWXYZ  
 1234567890?!@£&;”

## Wayfarer Semi Bold Italic

*abcdefghijklmnopqrstuvwxy*  
*ABCDEFGHIJKLMNOPQRSTUVWXYZ*  
*1234567890?!@£&;”*

## Wayfarer Bold

abcdefghijklmnopqrstuvwxy  
 ABCDEFGHIJKLMNOPQRSTUVWXYZ  
 1234567890?!@£&;”

## Wayfarer Bold Italic

*abcdefghijklmnopqrstuvwxy*  
*ABCDEFGHIJKLMNOPQRSTUVWXYZ*  
*1234567890?!@£&;”*

## Wayfarer Heavy

abcdefghijklmnopqrstuvwxy  
 ABCDEFGHIJKLMNOPQRSTUVWXYZ  
 1234567890?!@£&;”

## Wayfarer Heavy Italic

*abcdefghijklmnopqrstuvwxy*  
*ABCDEFGHIJKLMNOPQRSTUVWXYZ*  
*1234567890?!@£&;”*

# Secondary Typeface

The secondary typeface for Sheffield City Council is Arial - this will be used as the standard font for 'body text'.

This ensures our publications are produced in line with accessibility standards.

There are several type weights in the Arial family however the ones illustrated are suitable for body text.

Selected versions of Arial are standard on PC's and it is widely available from licenced font dealers.

## Arial MT Lt

abcdefghijklmnopqrstuvwxyz  
 ABCDEFGHIJKLMNOPQRSTUVWXYZ  
 1234567890?!@£&:;'"

## Arial SF MT

abcdefghijklmnopqrstuvwxyz  
 ABCDEFGHIJKLMNOPQRSTUVWXYZ  
 1234567890?!@£&:;'"

## Arial Rounded MT

abcdefghijklmnopqrstuvwxyz  
 ABCDEFGHIJKLMNOPQRSTUVWXYZ  
 1234567890?!@£&:;'"

## Arial MT Condensed Lt

abcdefghijklmnopqrstuvwxyz  
 ABCDEFGHIJKLMNOPQRSTUVWXYZ  
 1234567890?!@£&:;'"

## Arial MT Condensed

abcdefghijklmnopqrstuvwxyz  
 ABCDEFGHIJKLMNOPQRSTUVWXYZ  
 1234567890?!@£&:;'"



# Alternative Typefaces

Alternative typefaces may be used for creative title text on printed material as appropriate to the design, however not to create logotypes/nametypes for individual services.

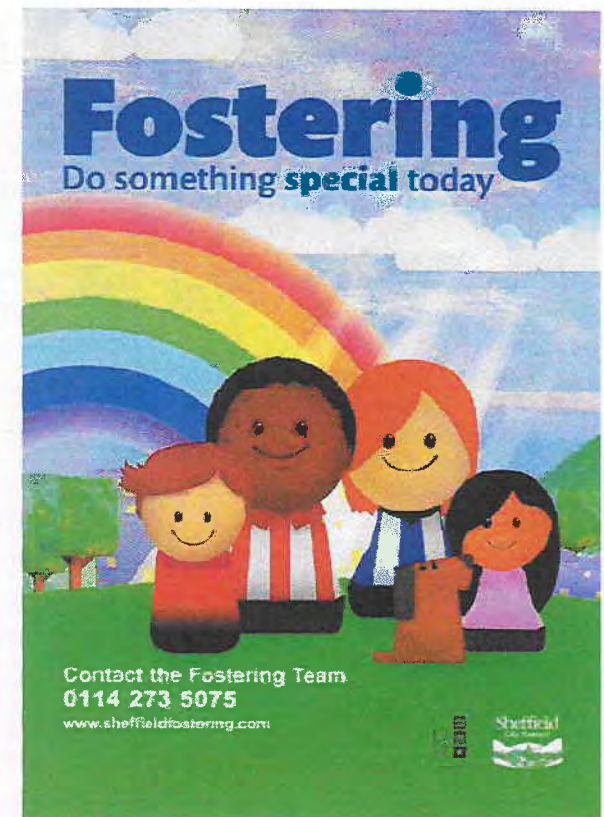
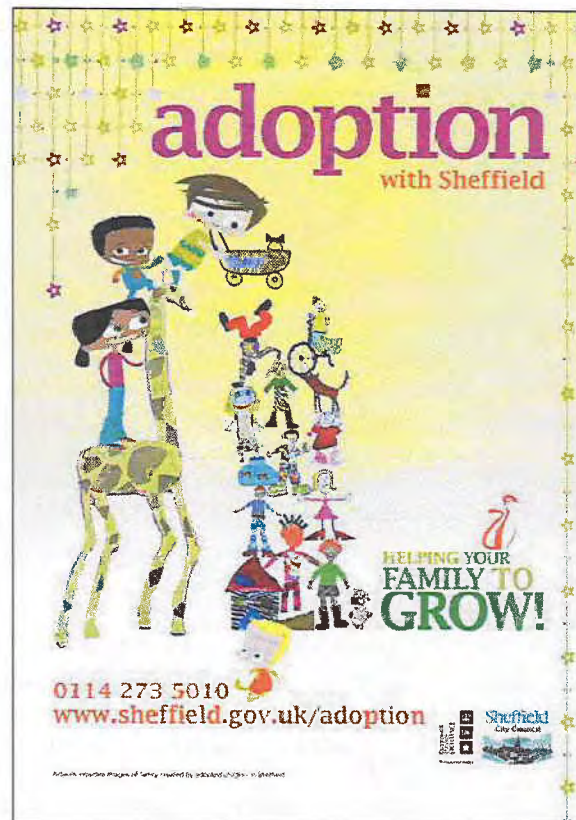

Blank for notes





# Press Advertising

The corporate advertisement border designs allow for a complete range of column widths. These are the only border styles that should be used.



**Sheffield City Council**



# Stationery

## On-line Stationery

There is one standard range of stationery for Sheffield City Council which can be ordered on-line. In the first instance contact Communications Service  
Tel: 0114 273 5538

## Letterhead

Letterhead - Includes the City Council logo and the Investor in People logo. The inclusion of other logos must be agreed by the Communications Manager - Creative Services Tel: 273 6640.

To achieve economies of scale on print, we encourage services to overprint their own details using the corporate blanks.

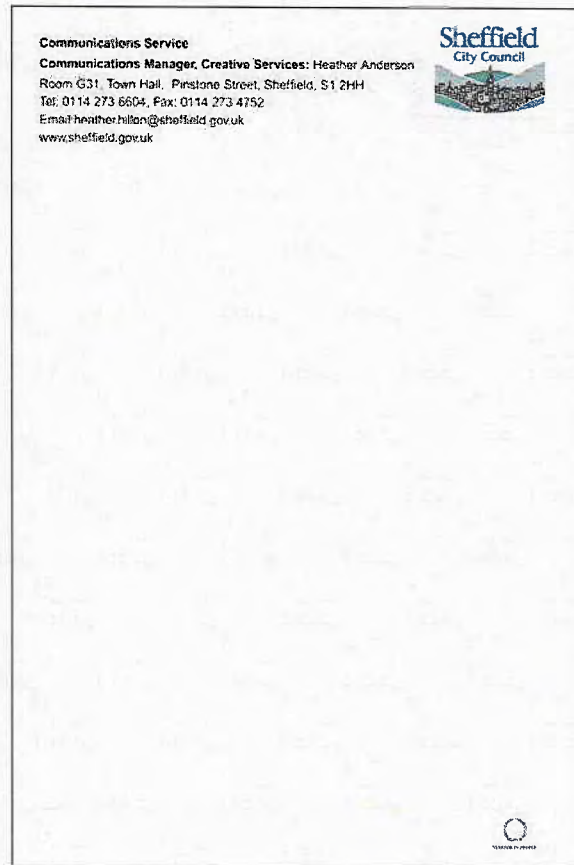

# Stationery

## Business Card, Compliments Slip and Corporate Stock Items

There is also a full range of corporate stock items available on our online ordering system. Contacts the Communications Service  
- Tel: 0114 273 5538

**Heather Anderson**  
**Communications Manager,**  
**Creative Services**



Town Hall, Pinstone Street, Sheffield, S1 2HH  
Tel: 0114 273 6604  
Fax: 0114 273 4752  
Mobile: 07944 924981  
heather.anderson@sheffield.gov.uk  
[www.sheffield.gov.uk](http://www.sheffield.gov.uk)

# Templates



**with compliments . [www.sheffield.gov.uk](http://www.sheffield.gov.uk)**

This is printed on 100% recycled paper, when you have finished with it please recycle it.



INVESTOR IN PEOPLE

# Templates

## Standard Document Templates

We have produced a range of A4 Word templates to help you prepare internal documents e.g. reports, covers, internal posters and leaflets.

These templates meet our Corporate Identity Standards.

You can download them from the intranet <http://intranet/communications>

A3 Word Templates and A5 Word Templates are also available to download for short run posters and leaflets.

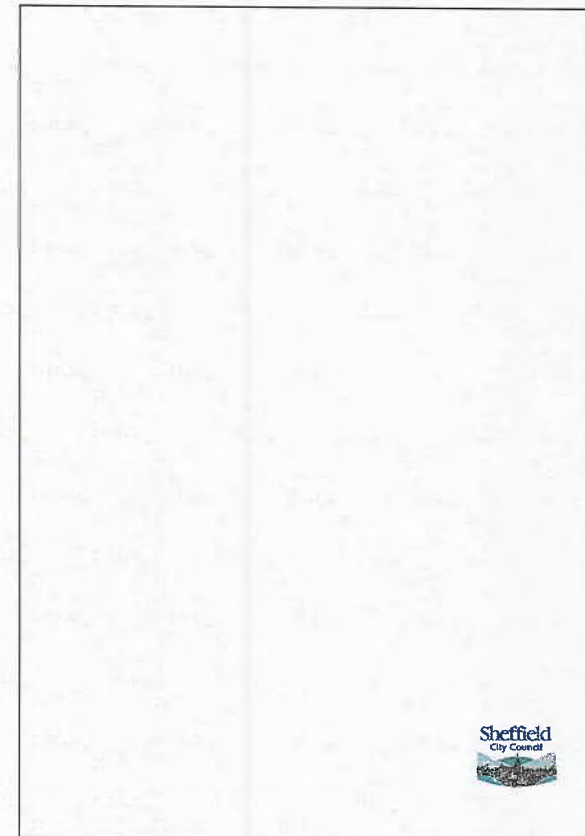
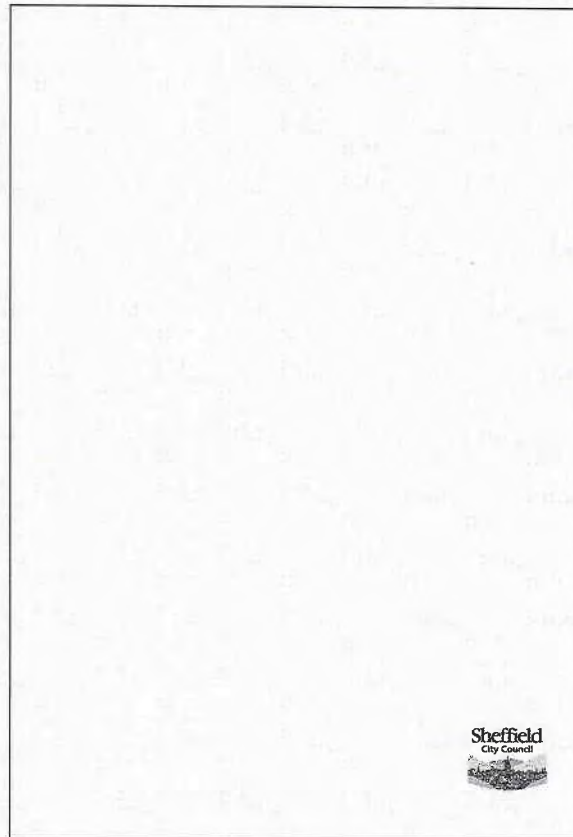



# Templates

## Powerpoint Templates

There is one standard powerpoint template available from Communications Service Tel: 0114 273 5538

## Instructions For Use

The first slide is the title slide and is branded in line with our corporate identity standards.

Use the second slide for the content of your presentation and just select the 'new slide' option in PowerPoint to add more slides.

This template replaces all previous versions and should be used for all Sheffield City Council presentations.

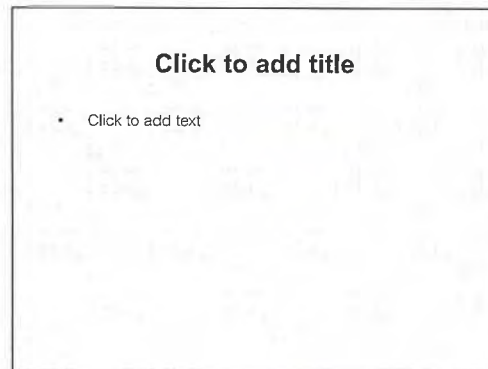
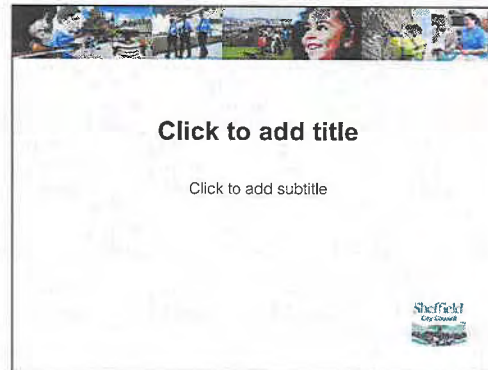



# Joint Branding

The Council works with many partners and sometimes promotional work needs to be joint branded. The corporate identity standards make provision for this.

If the Council is the lead organisation then the council identity should be applied with the inclusion of any funded partner or sponsor logos.

Where funded partnership exists between the Council and another organisation, our logo should appear on all promotional material and be given equal weight and prominence to any other logos.

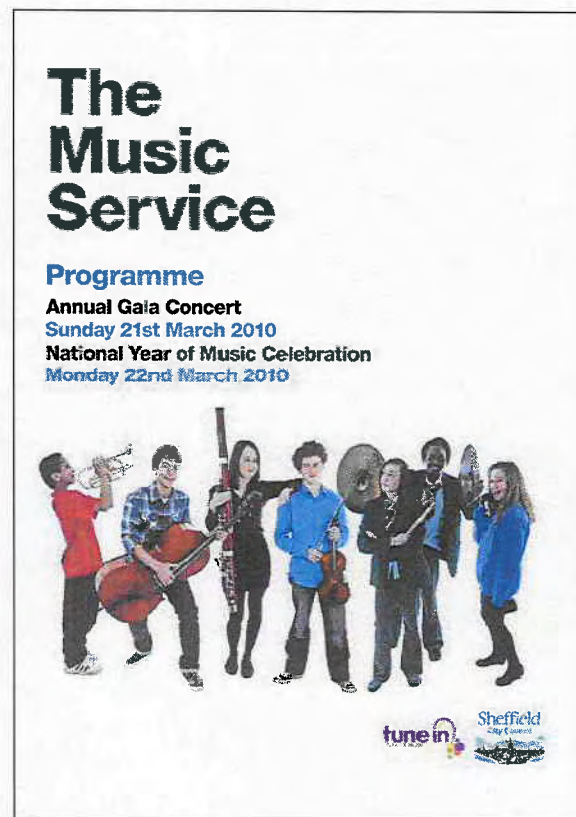

# Clothing

## Standard T-shirt

The Council logo should appear in full colour, solid white or solid black printed on the left hand front of a white, dark blue or dark green garment.

The service name may appear on the right hand side - however to achieve economies of scale we recommend the standard T-shirt.

## Event T-shirt

If the garment is for a specific campaign or event - the relevant styling/colourways can be included as illustrated.



# Clothing

## High Visibility Clothing

Hi visibility vests will carry the logo printed on the left hand side front and Sheffield City Council to the back.



Formal shirts, as worn by City Centre Ambassadors will carry the logo on the left hand breast pocket and post title on the right.

Outer garments - fleeces, jackets etc. should be dark blue or dark green with the Council logo.

Exclusions to this are firstPOINT staff, Town Hall Attendants, Parking Attendants and some safety clothing.



# Badges and Identity Cards

## Name Badges

There is one standard Council Name Badge design - this includes:

- Name
- Job Title

Available from Communications Service -  
Tel: 273 5538.



## Identity Cards

There is one standard Council identity Card design - certain details can be customised to suit specific needs.

Available from Communications Service -  
Tel: 273 5538.



# Awards

## Awards

Sheffield City Council has been awarded Investor in People status. Having achieved these standards the logos can be included on our recruitment and HR promotional material and stationery.

Investor in People logo can appear on the website, letterheads, compliments slips, recruitment information, management and training documents such as workforce plans and service plans.

## Other Recognised Awards

The inclusion of any other logos on printed items must be agreed with the Communications Manager - Creative Services Tel: 273 6604.

Some service areas have been achieved Customer Service Excellence and awarded Beacon Council status. These logos may also appear on publications specific to that service.



**INVESTOR IN PEOPLE**



The Government Standard



**2004-2005**  
*Transforming the School Workforce*  
**2008-2009**  
*Better Brighter Futures*



## Useful Contacts:

Communications Service: 0114 273 5538

email: [communications@sheffield.gov.uk](mailto:communications@sheffield.gov.uk)

<http://intranet/communications>

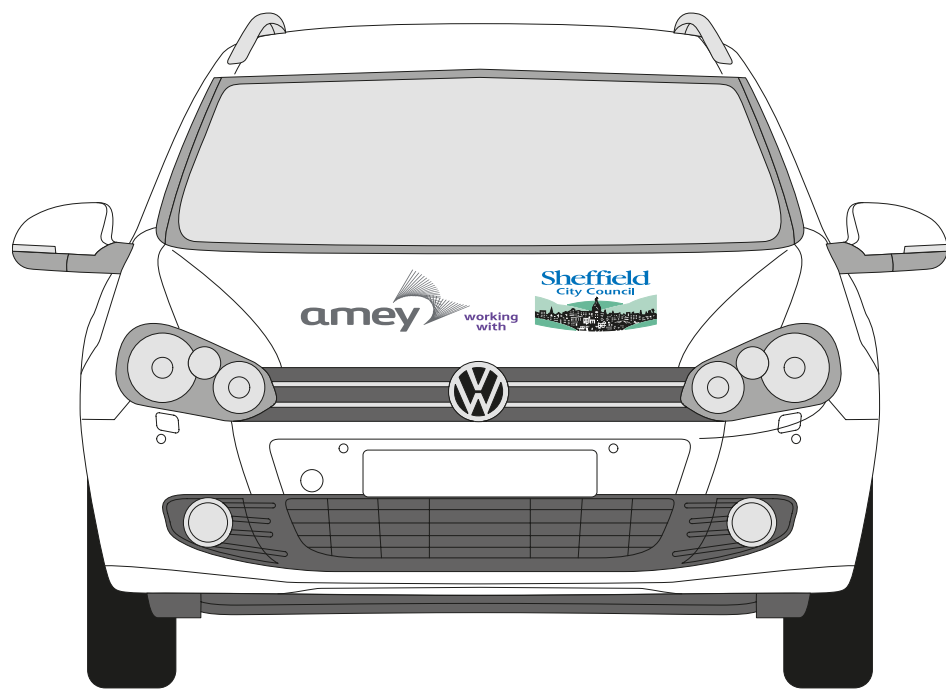

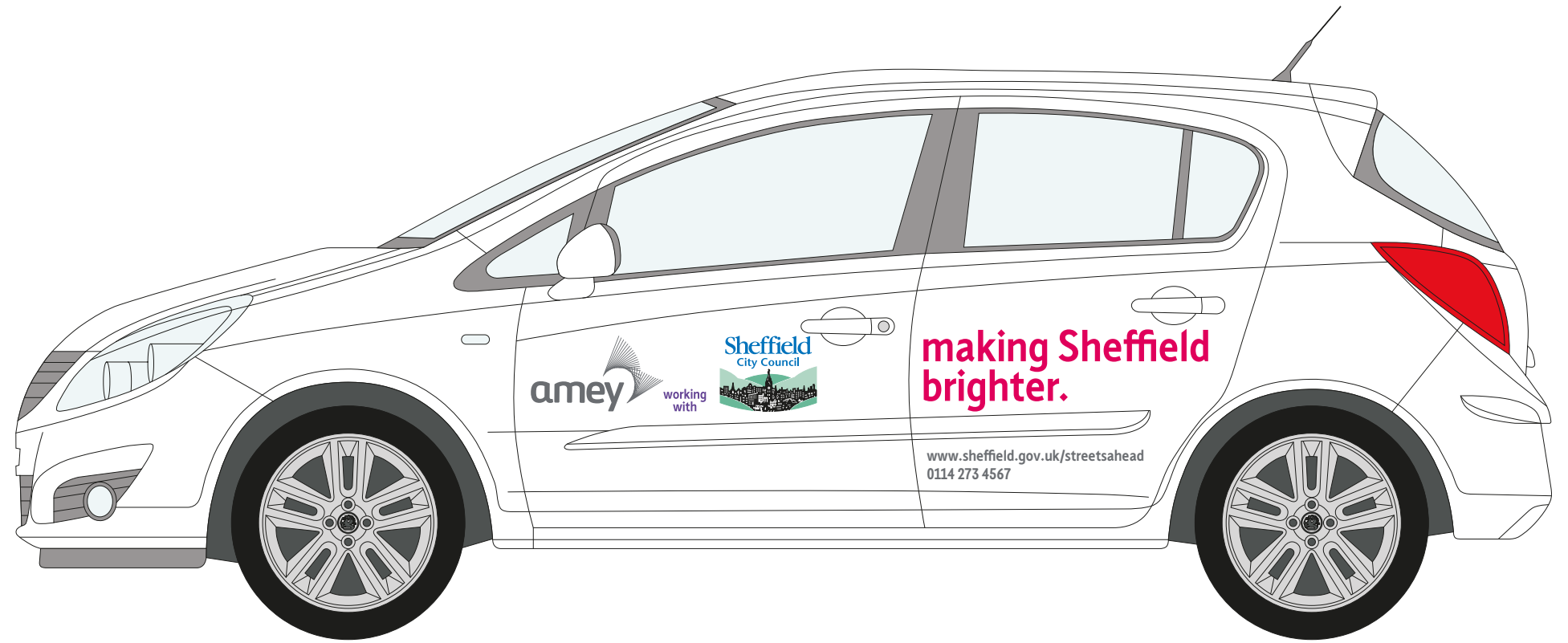
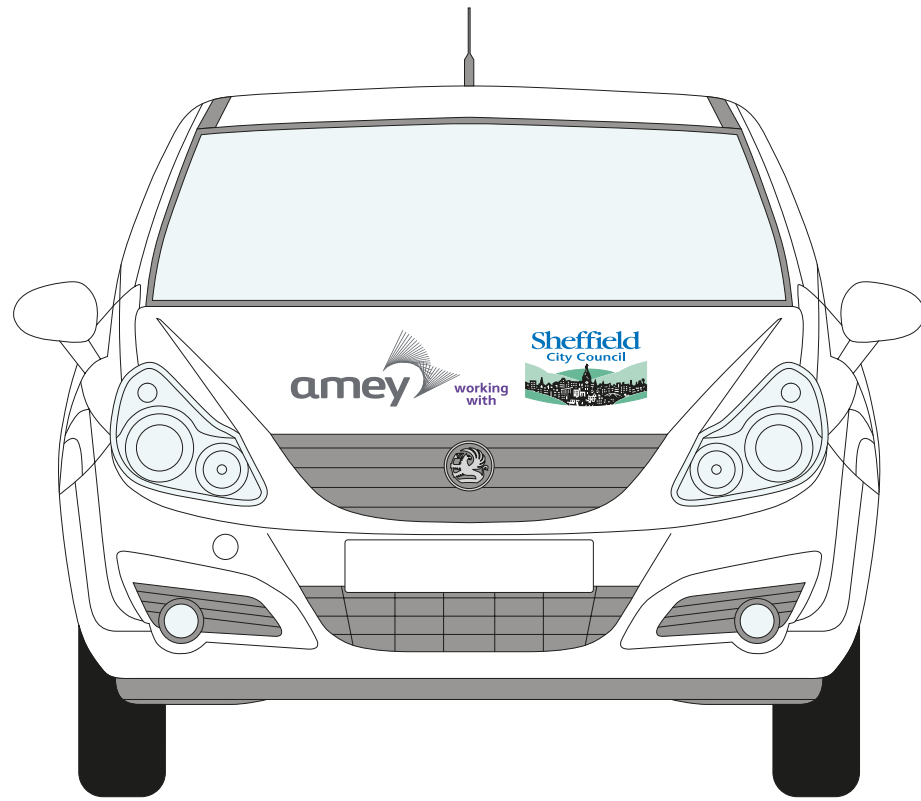

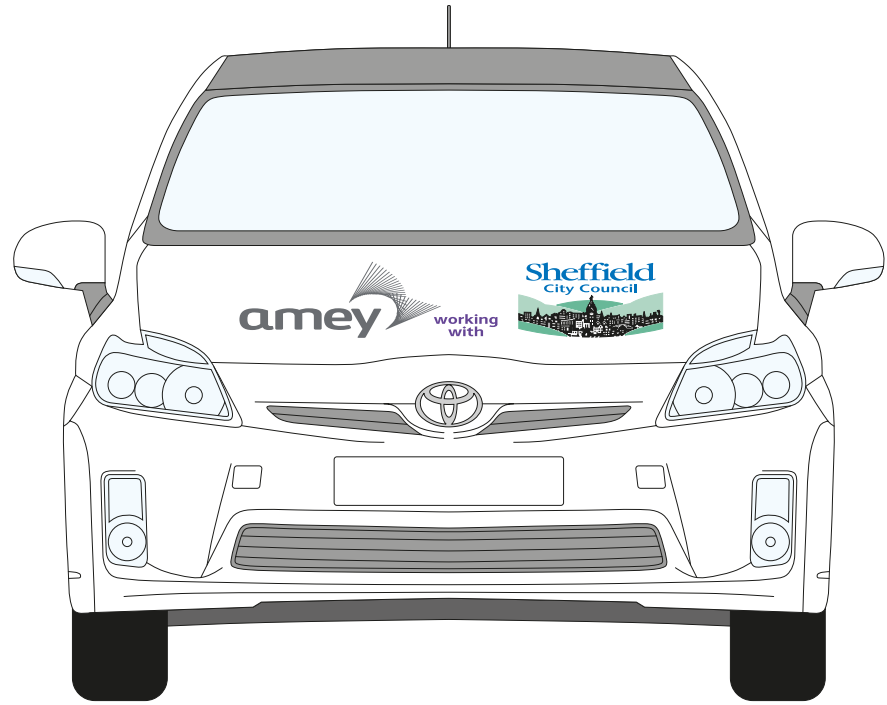





making Sheffield  
better.

Insert Title Here

Insert Sub Title Here



working  
with







**making Sheffield better.**

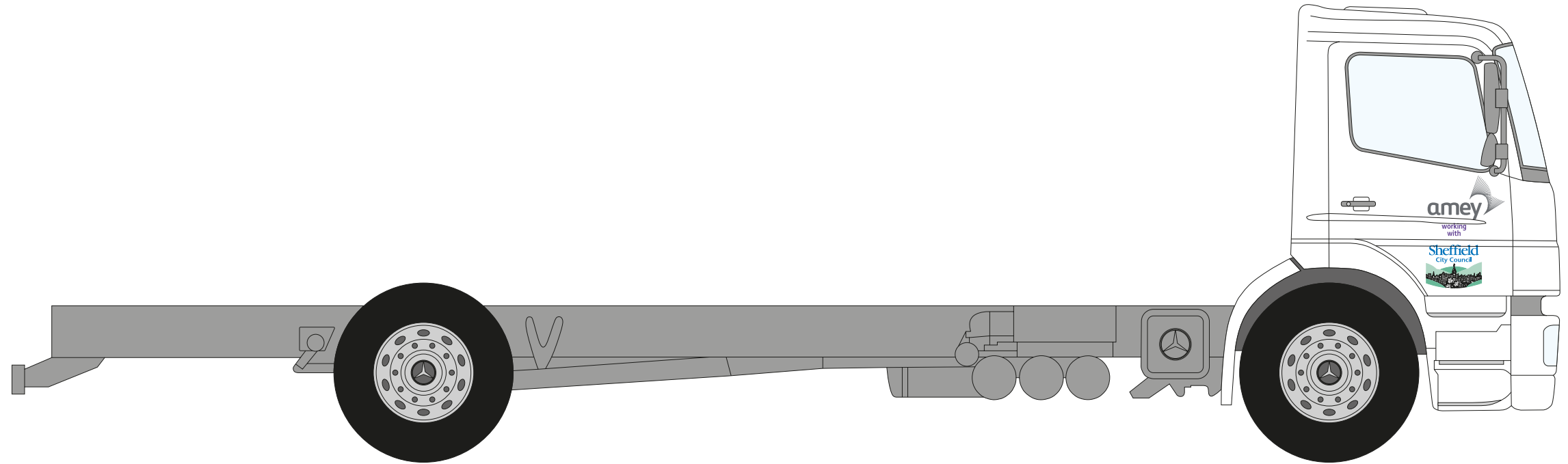
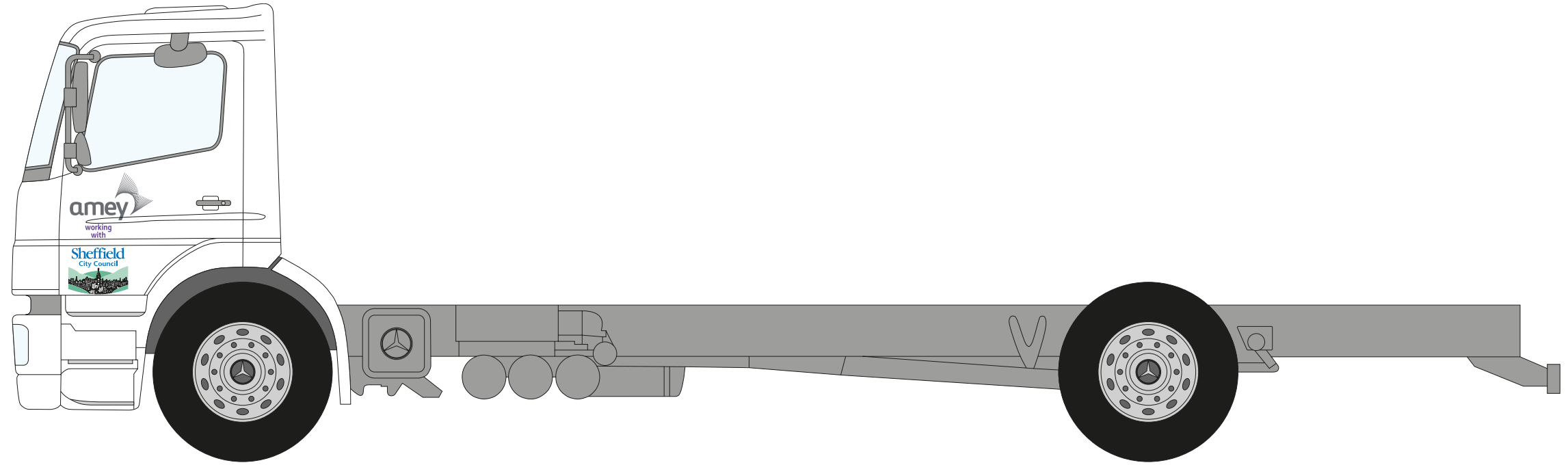
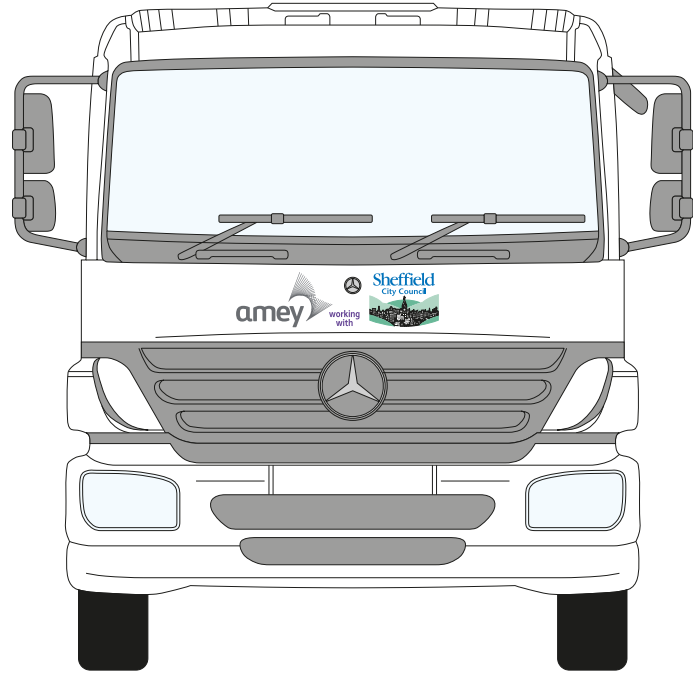

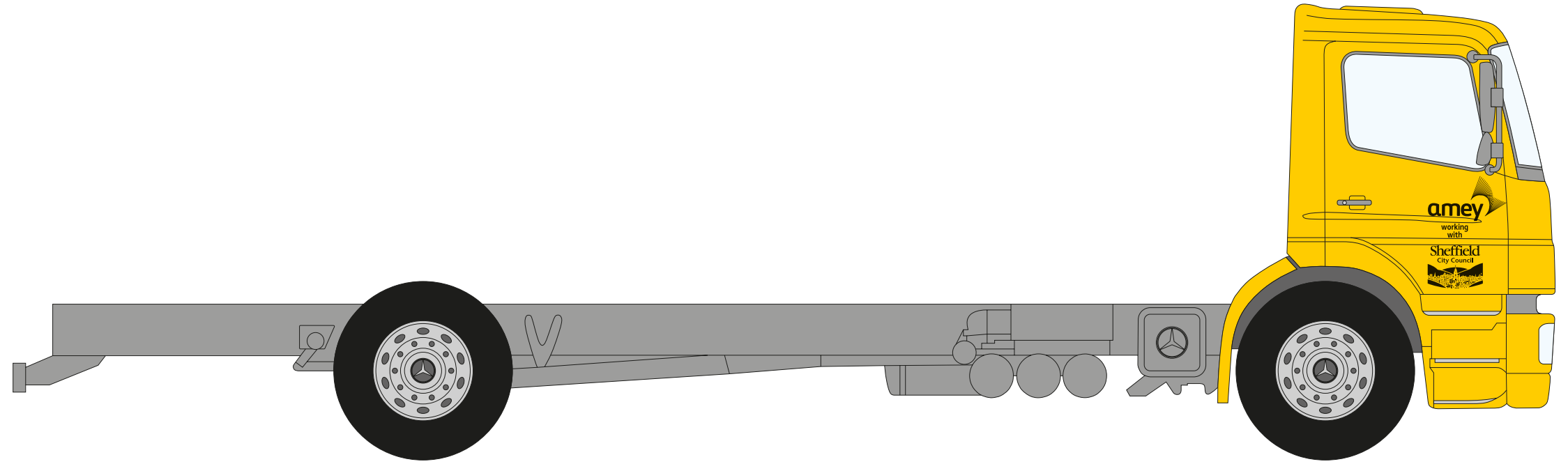
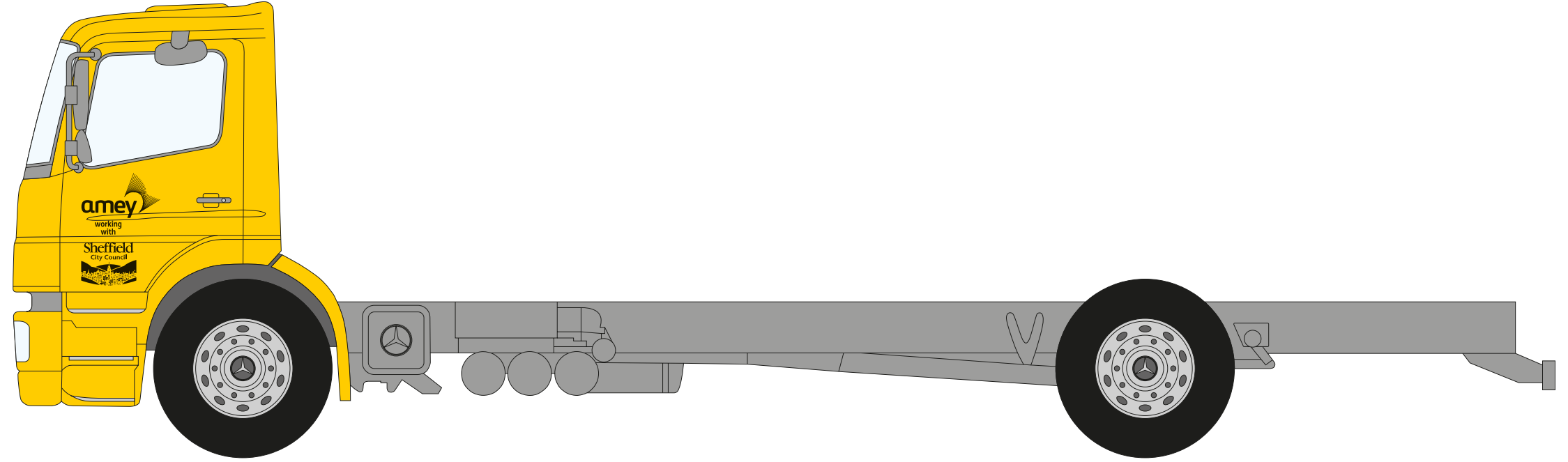
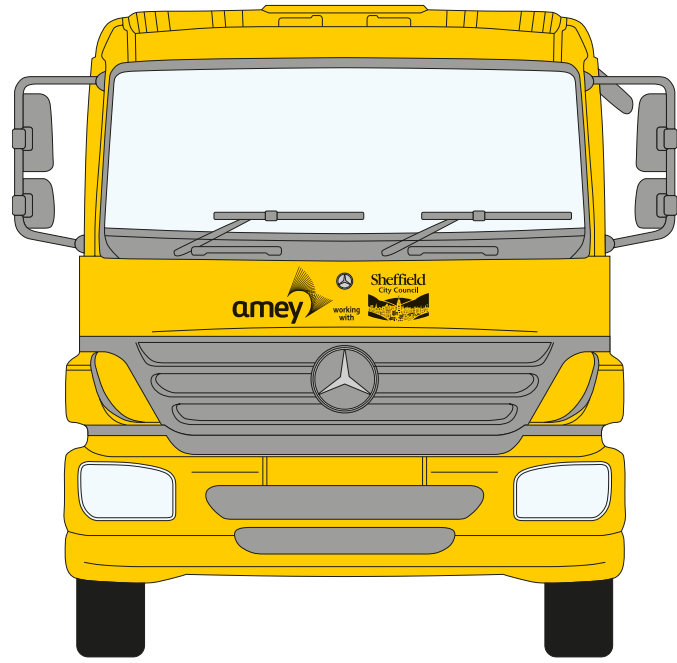

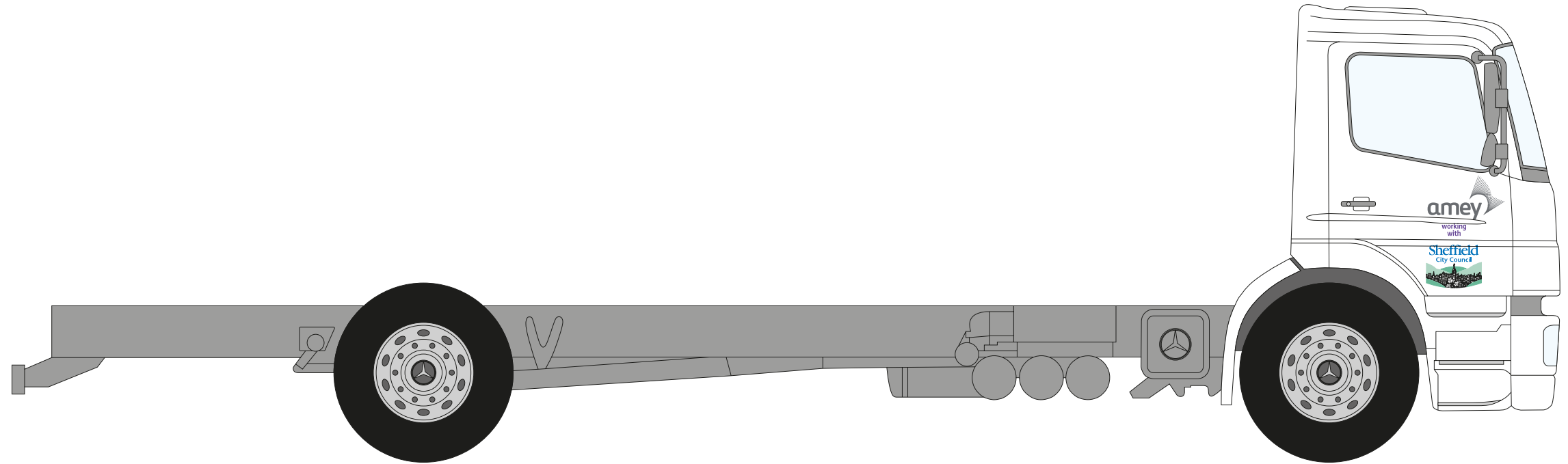
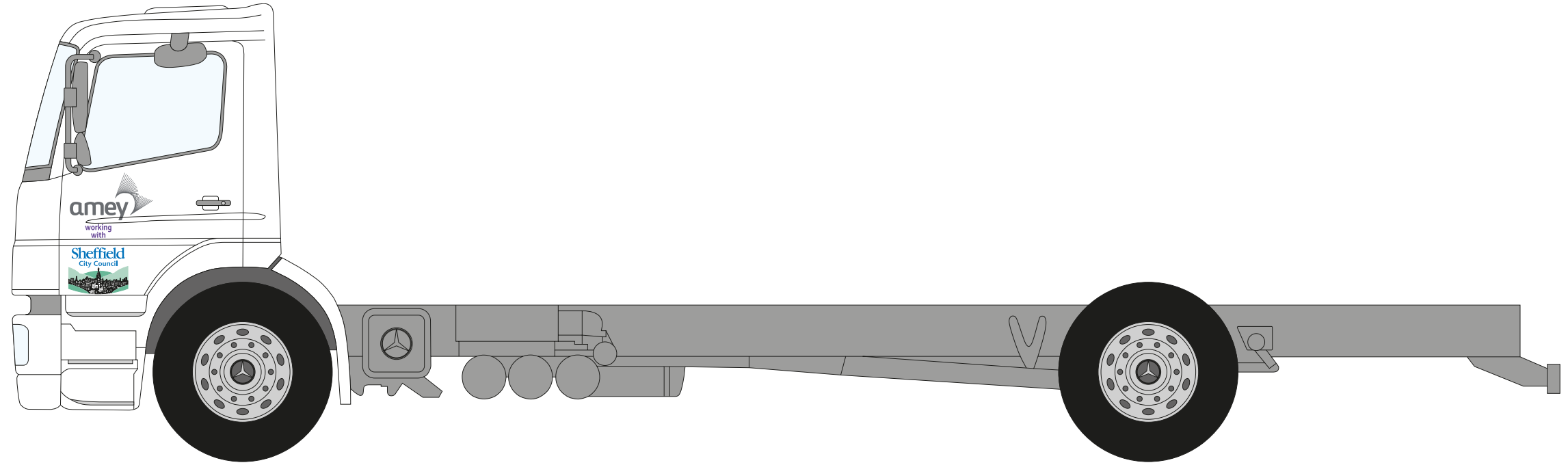
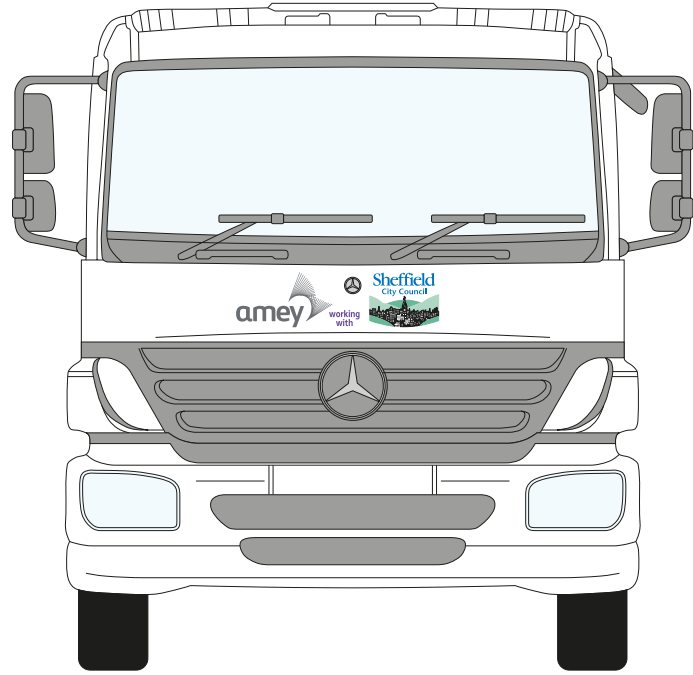



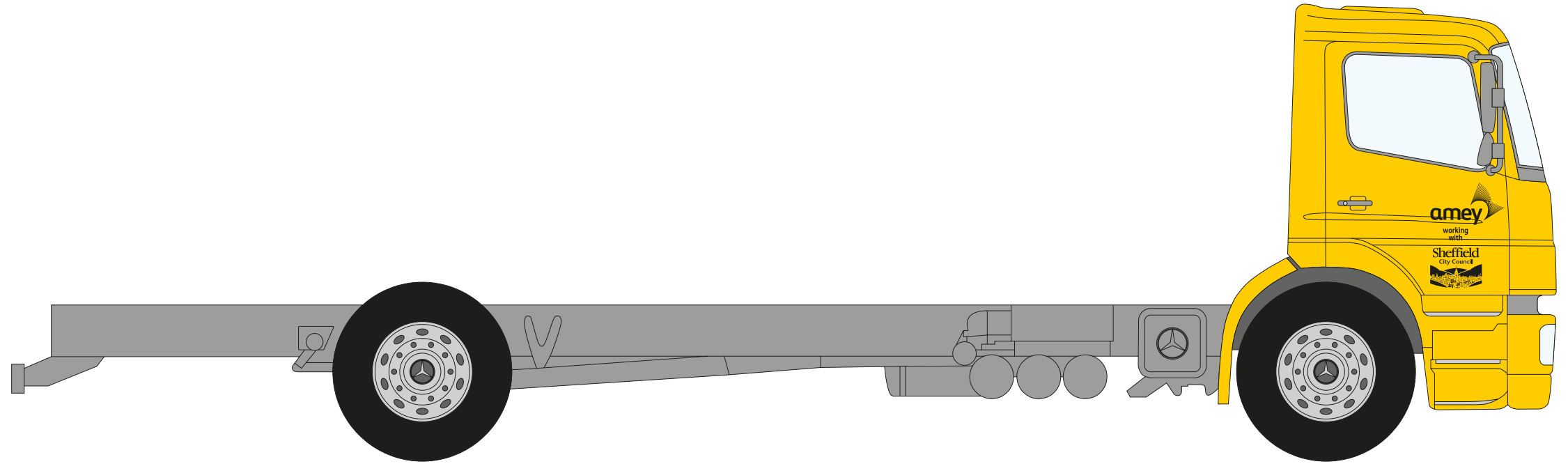
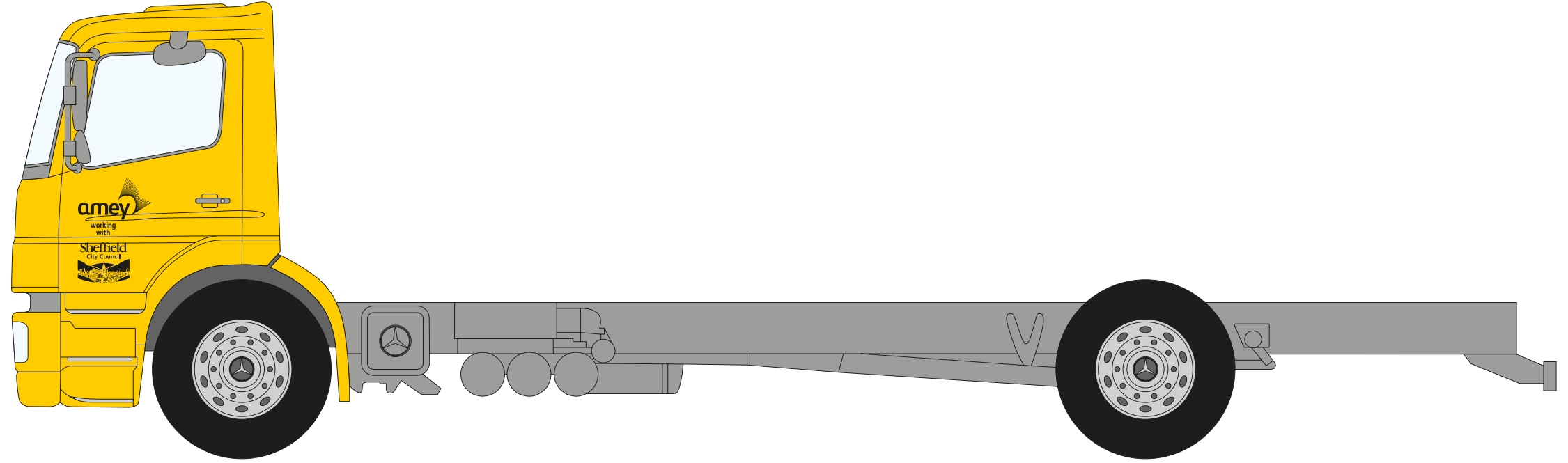

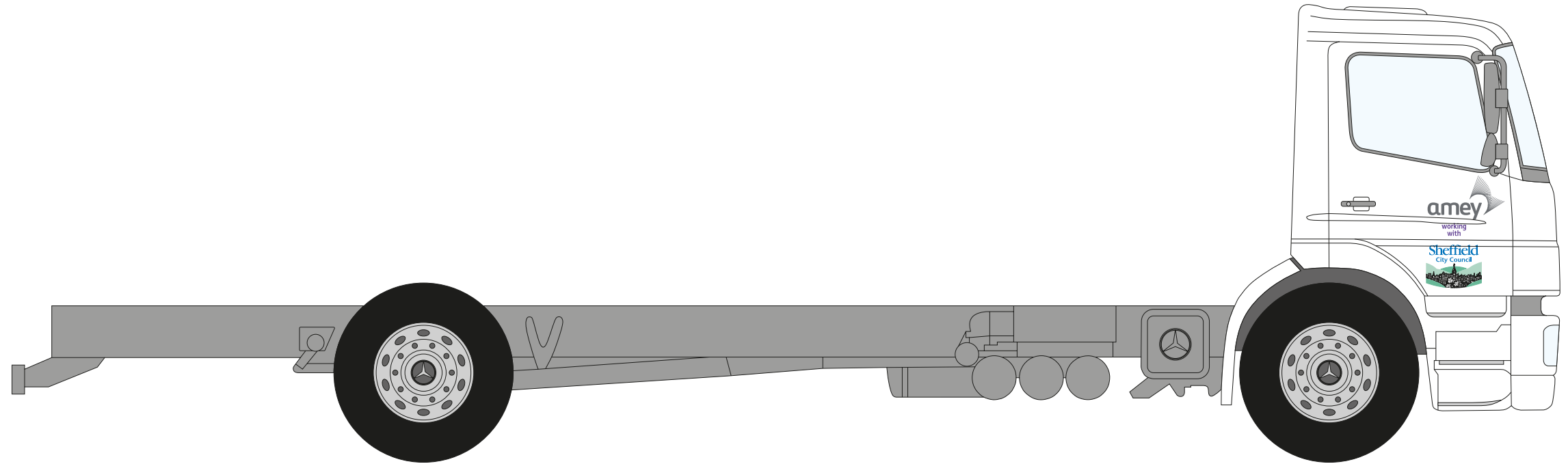
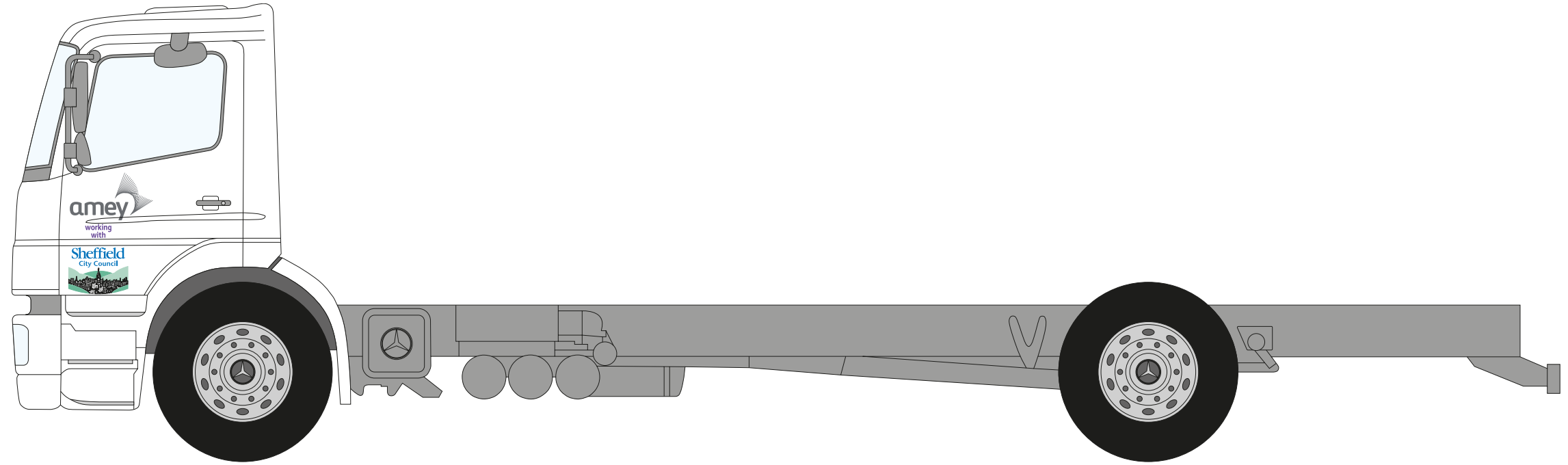
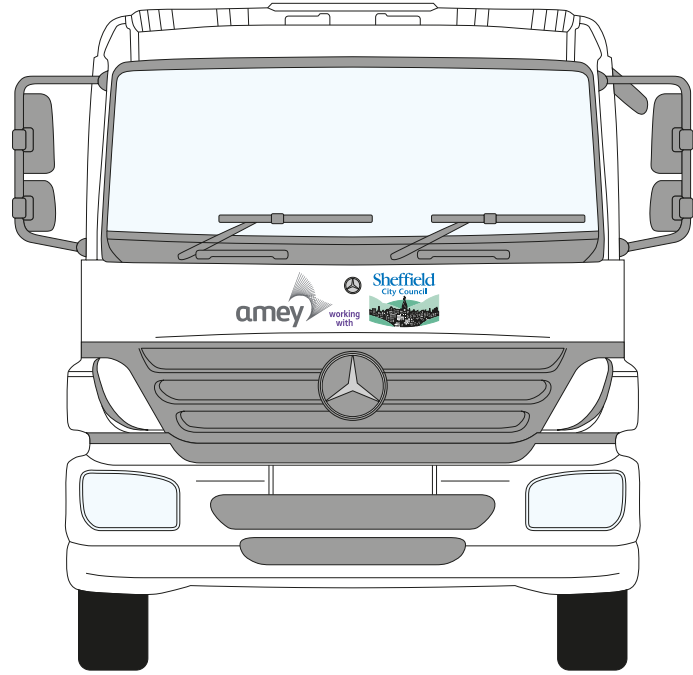

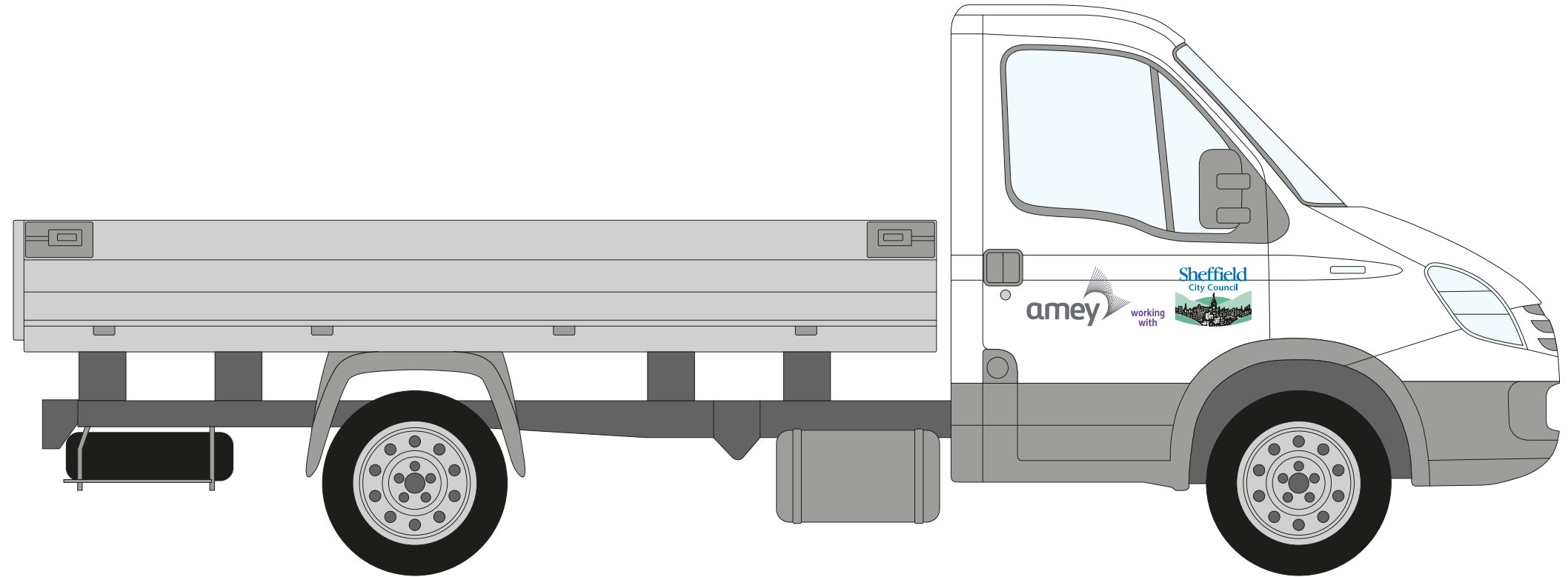
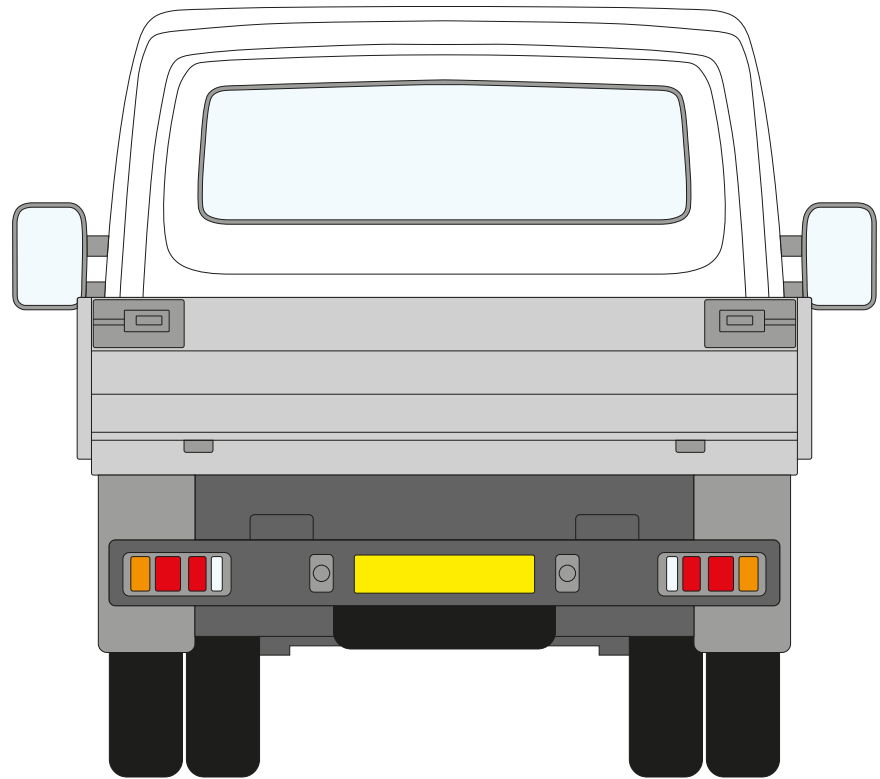
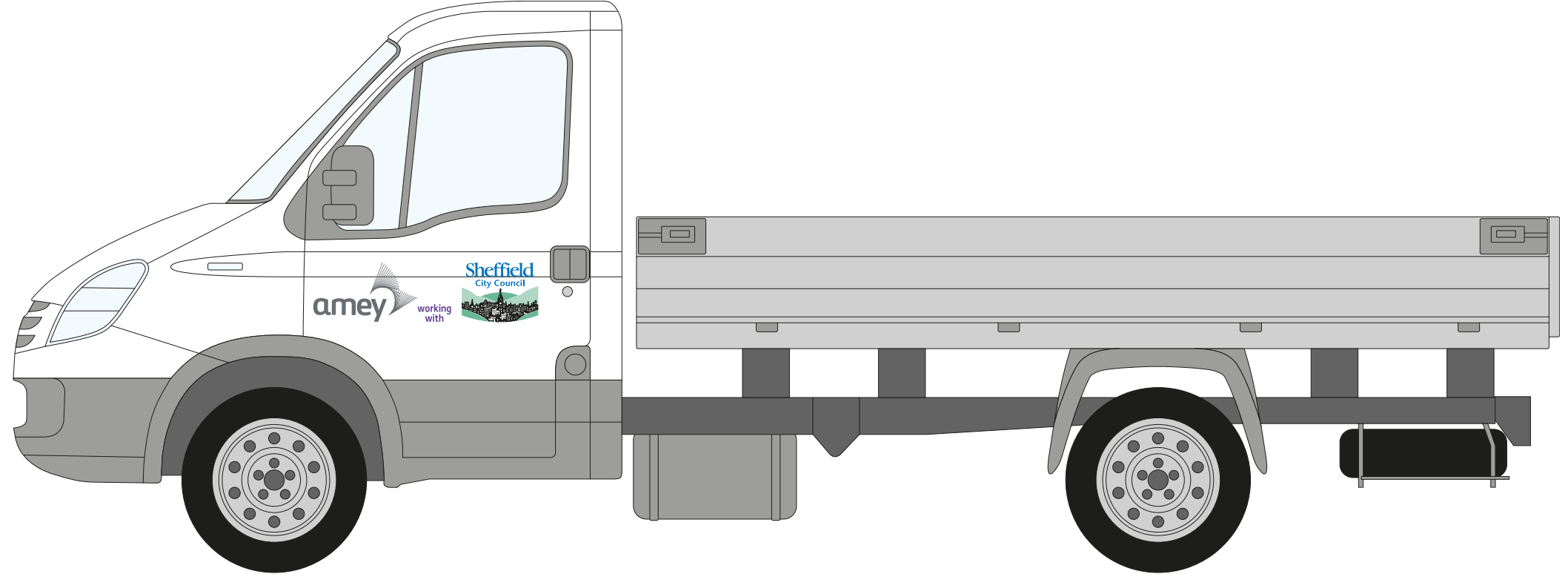
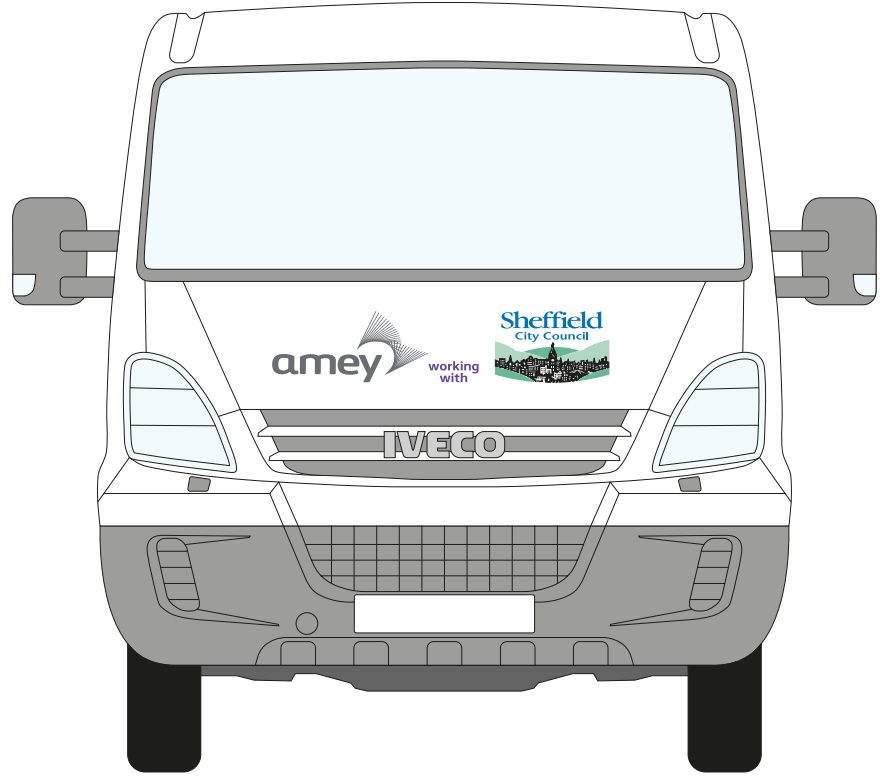



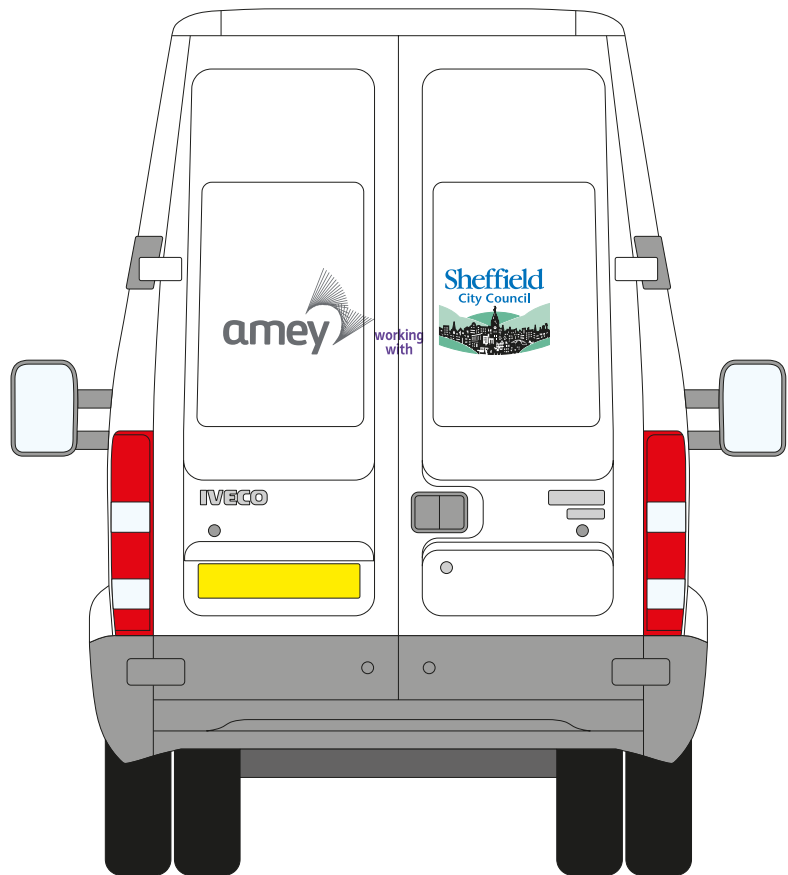
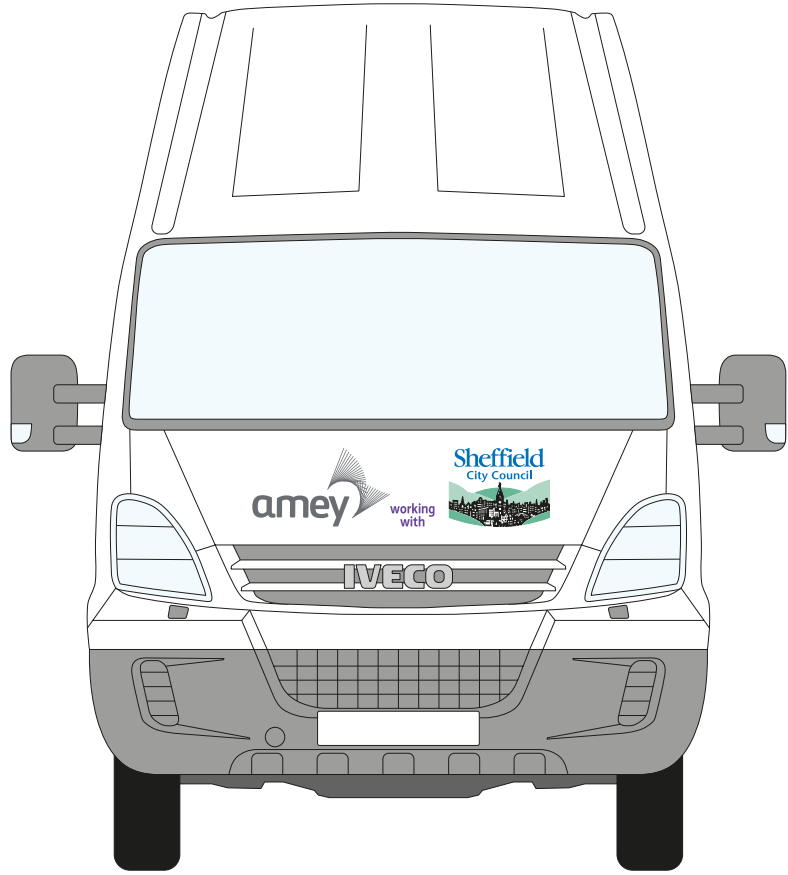

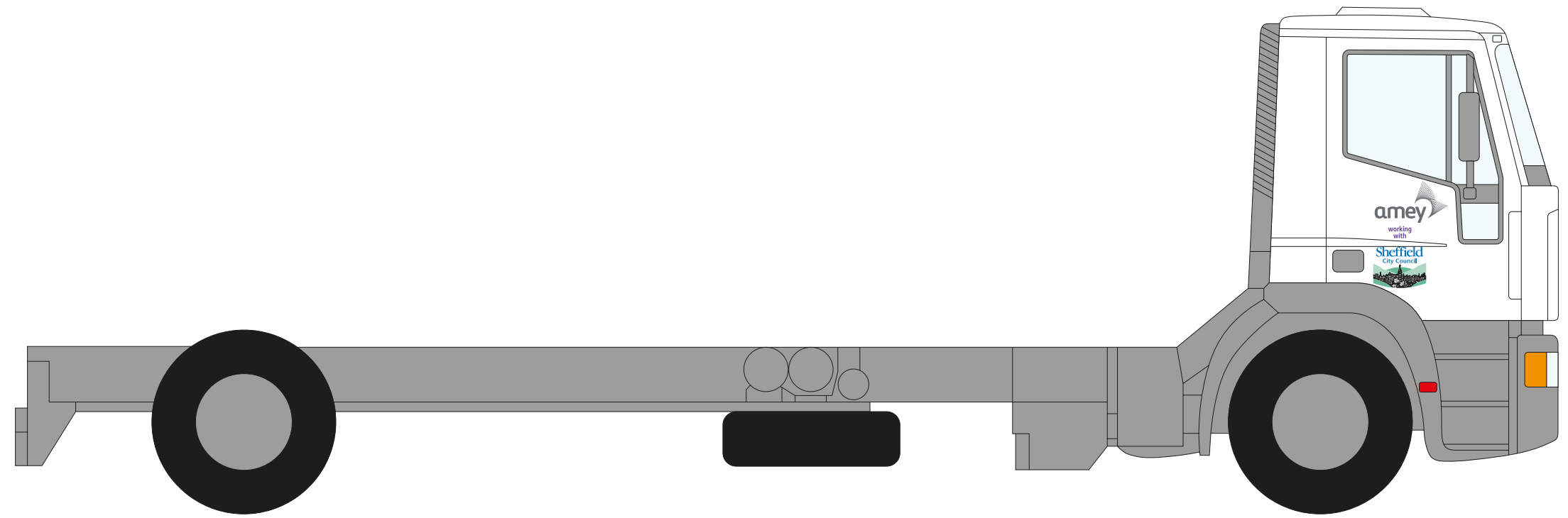
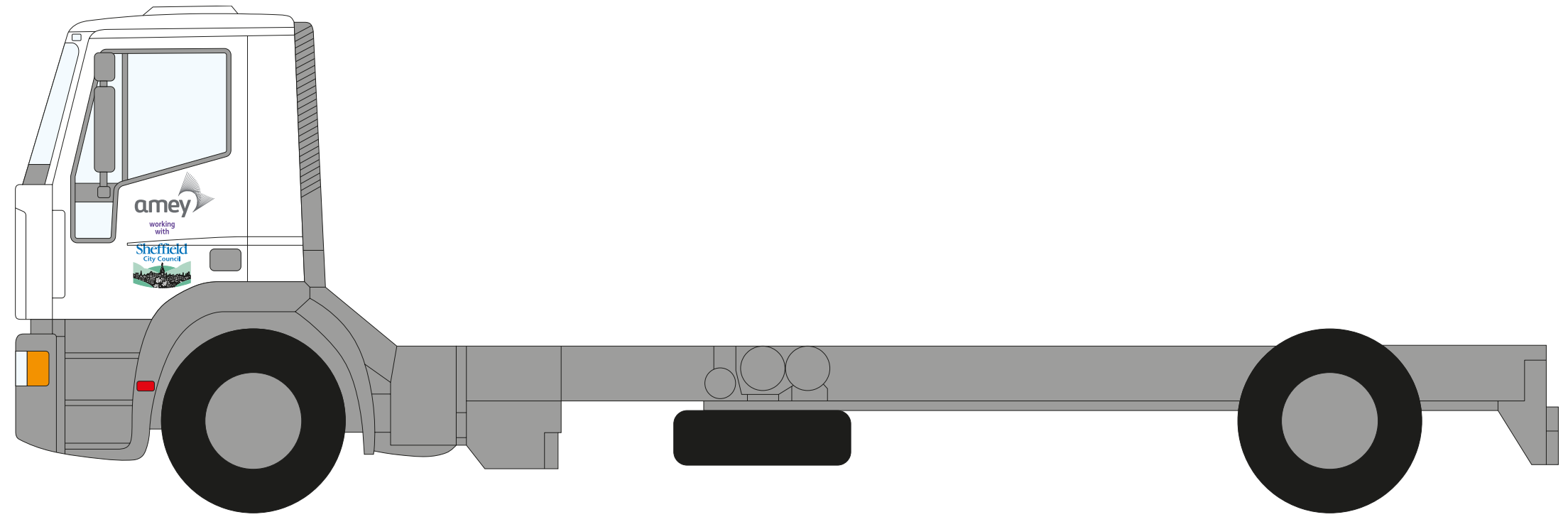
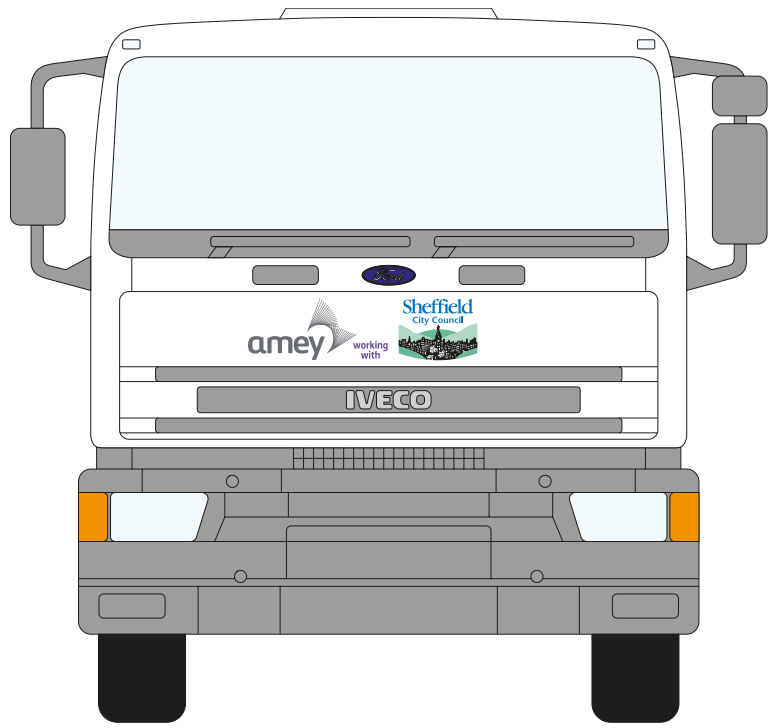

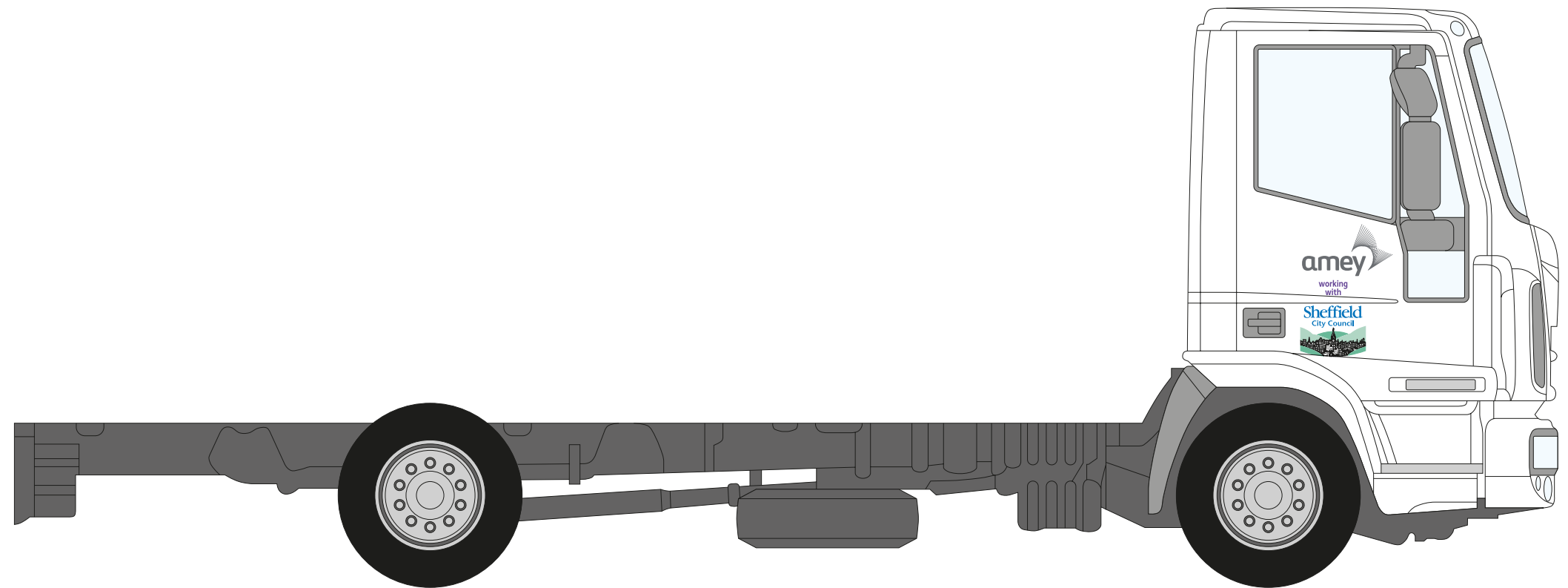
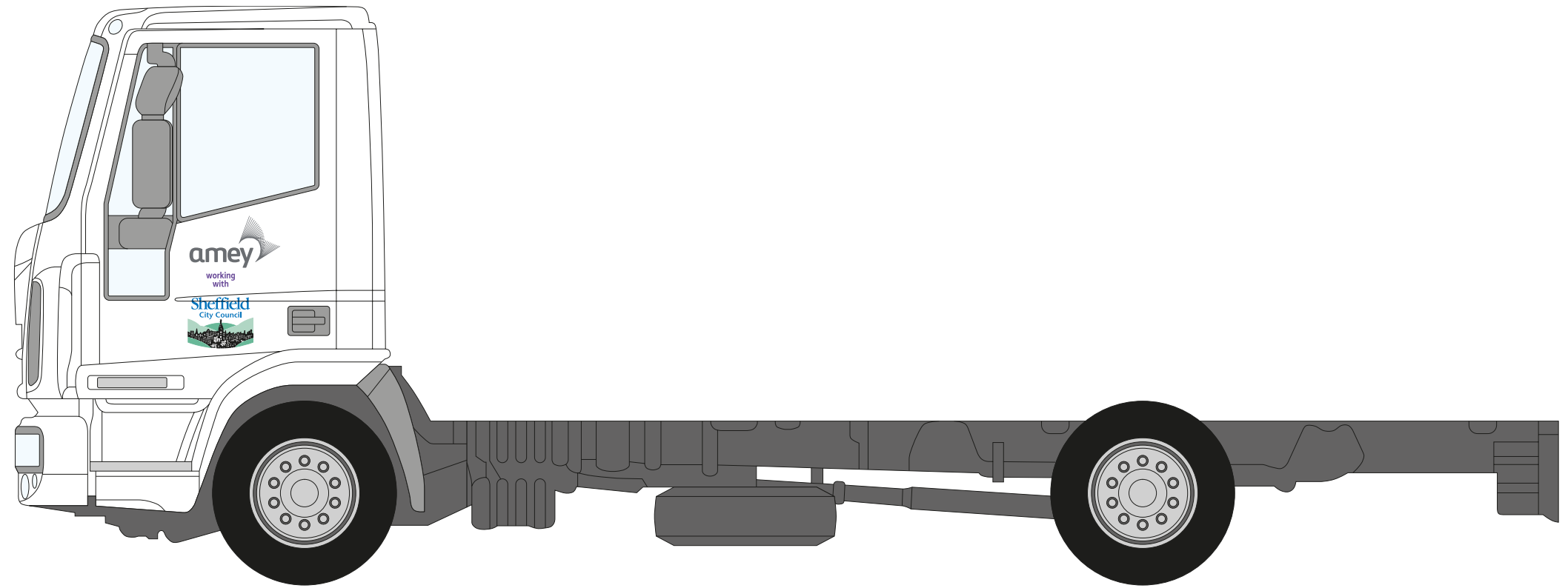
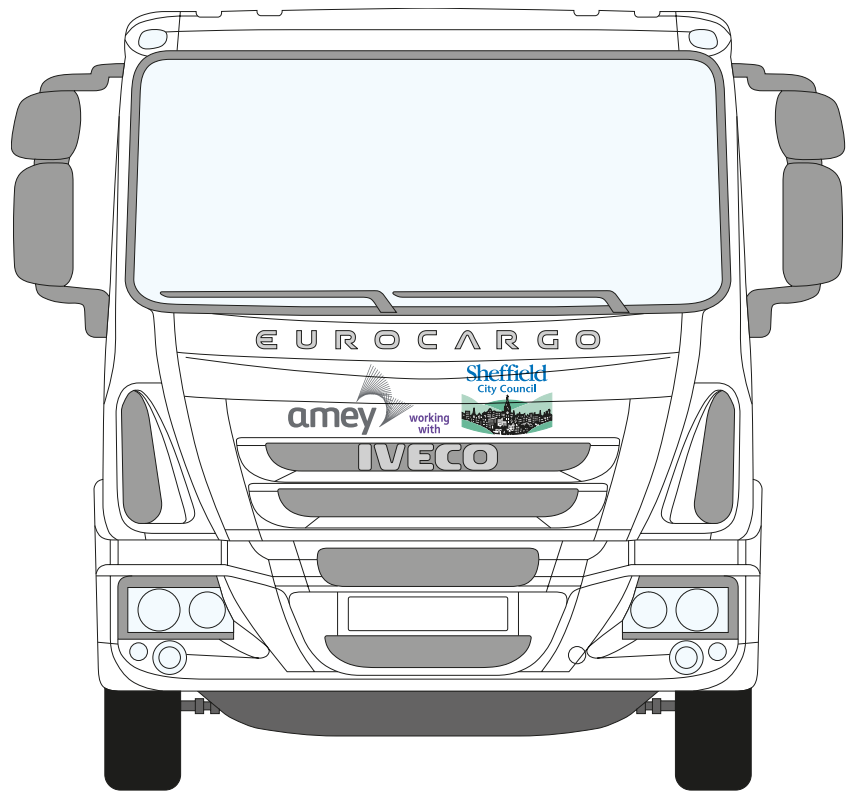



making Sheffield better.



Web: [www.sheffield.gov.uk/streetsahead](http://www.sheffield.gov.uk/streetsahead)

Email: [streetsahead@sheffield.gov.uk](mailto:streetsahead@sheffield.gov.uk)

Telephone: 0114 273 4567

Sheffield City Council Customer Services  
Howden House, Union Street, Sheffield, S1 2HH



# Your Guide to Sheffield's Street Ahead Works

making Sheffield better.



## This is your guide to the Street Ahead works.

It explains our plans to improve the city's roads, pavements, street lighting, bridges and streetscene. Inside you will find details about the types of works we're carrying out across the city and the benefits they will bring to you and your community. You will also find fact sheets that explain the nature of the improvement works being carried out in your area.

### **making Sheffield brighter.**

68,000 new energy efficient LED streetlights.

### **making Sheffield greener.**

36,000 healthier trees giving you greener streets.

### **making Sheffield smoother.**

1,180 miles of improved roads giving a smoother ride.

### **making Sheffield safer.**

2,050 miles of improved pavements making it easier underfoot.



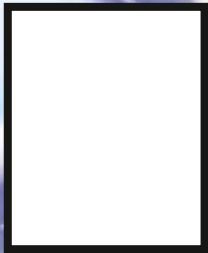

**First Name Surname**

Job Title

Address Line 1

Address Line 2

Tel: 0114 123 4567



working  
with



## First Point

Howden House, Union Street, Sheffield, S1 2HH

Tel: 0114 273 4567

Email: [streetsahead@sheffield.gov.uk](mailto:streetsahead@sheffield.gov.uk)

[www.sheffield.gov.uk/streetsahead](http://www.sheffield.gov.uk/streetsahead)



working  
with



**making Sheffield  
better.**



## First Point

Howden House, Union Street, Sheffield, S1 2HH

Tel: 0114 273 4567

Email: [streetsahead@sheffield.gov.uk](mailto:streetsahead@sheffield.gov.uk)

[www.sheffield.gov.uk/streetsahead](http://www.sheffield.gov.uk/streetsahead)



working  
with



**making Sheffield  
brighter.**

**68,000 new energy efficient  
LED streetlights.**

## First Point

Howden House, Union Street, Sheffield, S1 2HH

Tel: 0114 273 4567

Email: [streetsahead@sheffield.gov.uk](mailto:streetsahead@sheffield.gov.uk)

[www.sheffield.gov.uk/streetsahead](http://www.sheffield.gov.uk/streetsahead)



working  
with



making Sheffield  
smoother.

1,180 miles of improved roads  
giving a smoother ride.

## First Point

Howden House, Union Street, Sheffield, S1 2HH

Tel: 0114 273 4567

Email: [streetsahead@sheffield.gov.uk](mailto:streetsahead@sheffield.gov.uk)

[www.sheffield.gov.uk/streetsahead](http://www.sheffield.gov.uk/streetsahead)



working  
with



**making Sheffield  
safer.**

**2,050 miles of improved pavements  
making it easier underfoot.**

## First Point

Howden House, Union Street, Sheffield, S1 2HH

Tel: 0114 273 4567

Email: [streetsahead@sheffield.gov.uk](mailto:streetsahead@sheffield.gov.uk)

[www.sheffield.gov.uk/streetsahead](http://www.sheffield.gov.uk/streetsahead)



working  
with



**making Sheffield  
greener.**

**36,000 healthier trees giving  
you greener streets.**



relevant image required

## Safer, more reliable safety barriers coming soon

Sheffield's highway fences, bollards and barriers are essential in making sure pedestrians and vehicles can move freely and safely.

Our city's street furniture for example benches and seating, cycle stands and artefacts all help to make Sheffield an attractive place to live, work and visit. Therefore it is important that that these assets are well maintained.

As part of the Streets Ahead project we will be cleaning, repairing or replacing where necessary the city's street furniture, as well as

making Sheffield's roads and pavements safer by upgrading and installing new safety fencing and pedestrian barriers where necessary.

More information can be found at [www.sheffield.gov.uk/streetsahead](http://www.sheffield.gov.uk/streetsahead)



## Did you know?

Our Streets Ahead provider is responsible for maintaining on our behalf:

- 142 public benches
- 14,025 bollards
- 690 cycle barriers
- 388 cycle stands
- 18,637metres of handrail
- 493 tree grills (these protect the trees roots to allow healthy, natural growth)
- 724 public seats
- 30, 219 metres of safety fencing
- 208 artworks and artefacts

relevant  
image  
required

making Sheffield better.



## Improved signage and technology coming soon

As part of the Streets Ahead project, we'll be improving the safety of our city by making sure that there is fully functional traffic signals to manage traffic flows and minimise congestion, appropriate pedestrians crossings to help people across busy roads, and good quality signage and street nameplates for easy travel.

### In the first five years

Our planned improvement works will see approximately 25 per cent of our traffic lights

replaced over a period of five years between 2012 and 2017, known as the core investment period, of the 25 year contract.

More information can be found at [www.sheffield.gov.uk/streetsahead](http://www.sheffield.gov.uk/streetsahead)



working  
with



Also during this time our Streets Ahead provider, Amey, will be:

- Repairing traffic detection at traffic lights so that they function correctly and efficiently
- Introducing above ground traffic detection wherever possible to improve the efficiency of future maintenance works - we won't need to dig up the roads again to fix any future faults
- Replacing corroded and damaged signal poles
- Painting all the signal poles black
- Replacing electronic signage around Meadowhall to guide shoppers to the nearest available car park



## Did you know?

Our Streets Ahead provider is responsible for maintaining on our behalf:

- 297 traffic signal junctions
- 201 pedestrian crossings
- 110 variable message signs

**making Sheffield better.**



# New litter and recycling bins coming soon

Our aim is to maintain a high-quality environment in Sheffield that is clean, safe, vibrant, welcoming and attractive. As part of the Streets Ahead project, we'll be installing over 1,000 new litter and recycling bins to encourage more people to dispose of their waste responsibly and keep our city tidy.

Our Streets Ahead provider, Amey, is responsible for our street cleaning service on our behalf, which includes the removal of:

- litter
- graffiti
- dead animals from the highway
- flytipping
- flyposting
- gully cleaning

They will also install, repair and empty litter bins on our behalf throughout the 25 year Streets Ahead contract.

## In the first five years

1,000 new litter and recycling bins will be introduced across the city in the first five years, known as the core investment period, of the 25 year contract.

We've also invested in some new solar powered mechanical bins that conveniently tell us when they're full. The power generated by the sun allows the bin to crush and compact the rubbish inside at regular intervals so that it can accommodate more waste. The bins will be strategically positioned in the city's more rural areas where the bins tend to require emptying less frequently.

These mechanical compressing bins will mean that our Streets Ahead provider, Amey, can deliver a more efficient cleaning service for the city. It eliminates the need for spot checks and reduces unnecessary journeys meaning we can focus on cleaning Sheffield's litter hot spots.

More information can be found at [www.sheffield.gov.uk/streetsahead](http://www.sheffield.gov.uk/streetsahead)



working  
with



## Did you know?

- There are over 2,500 litter bins across Sheffield. 1,000 more are being installed as part of the Streets Ahead project.
- It is a criminal offence to drop litter or throw it from a car and you could be fined £75
- Biodegradable things like apple cores, banana skins, even breadcrumbs is litter

## Help keep Sheffield tidy

Litter is the most visible sign of pollution. It is unsightly and can cause harm to people, wildlife and pollutes our waterways. It encourages pests as well as the spread of germs and diseases. You can help us by:

- Not dropping litter on the street
- Ensuring that litter bins are not overfilled – use the next available bin to dispose of your waste
- Not disposing of household rubbish in our public litter bins
- Clearing up after your dog – disposing of it safely and appropriately in a litter bin



**making Sheffield better.**

# Brighter, more energy efficient streetlights coming soon

We know that good quality street lighting is an important factor in helping to reduce crime and the fear of crime; whilst improving road safety.

As part of the Streets Ahead project, your current street lighting is being replaced with state-of-the-art Light Emitting Diode (LED) technology designed to improve the overall quality of our street lighting network across our city. The LED lighting will provide brighter 'white light' to improve visibility and safety as well as reducing carbon emissions.

## In the first five years

We'll be replacing and repositioning over 58,000 street lighting columns across the city. To do this we'll need to carry out excavation works in the pavement to connect the new lighting to the electricity cable. We will inform you by letter when we will be replacing street lights.

## How will the new lighting differ?

Your new street lighting will look significantly different to what you are used to mainly because of new street lighting positions. It is very likely that your new lighting columns will be sited in different positions on your street.

This is to make sure that there is an even distribution of light that meets current British standards. Each street across Sheffield will have a unique street lighting design that takes into account things such as the type of road you live on, the current streetscene, the height of houses and buildings and the number of trees on the street.

More information can be found at [www.sheffield.gov.uk/streetsahead](http://www.sheffield.gov.uk/streetsahead)



working  
with



## Benefits of the new lighting

There are many benefits the new street lighting will bring to you and your community including:

- Improved community safety (the 'white light' allows a wider spectrum of colours to be seen and facial features to be distinguished. As a result, many people feel safer)
- Reduced energy use and light pollution (LEDs are more energy efficient and will help to reduce current carbon emissions by over 50 per cent)
- An even distribution of light
- Reduced risk to motorists
- A central control monitoring system (After the five years replacement programme the LEDs will be managed by this system which will automatically detect when lights are not operating correctly. Therefore we will no longer be reliant on inspections and public reports. This system also allows us to optimise lighting levels based on road usage and circumstances)



## Did you know?

Our Streets Ahead provider is responsible for maintaining on our behalf:

- 68,000 street lighting columns
- 5,000 other electrically powered apparatus
- 7,000 illuminated signs
- 1,000 illuminated bollards

**making Sheffield brighter.**

**68,000 new energy efficient LED streetlights.**



# Clean and clear highway gullies and drains coming soon

As part of the Streets Ahead project, we have plans to inspect and repair flood prone gullies and drains across the city. For the first time they will be visually inspected to understand their condition and our Streets Ahead provider, Amey, is developing a planned programme of improvement works and repairs.

These works vary from simply replacing gully grates and pots to more complex works like installing completely new drainage systems to improve the removal of water from the highway. These works are essential and will significantly help prevent flooding in the future.

## In the first five years

We'll be carrying out 129 improvement drainage schemes across the city within the first 5 years between 2012 – 2017 known as the core investment period, of the 25 year contract.

Also we'll be replacing 3,000 sub-standard gullies across the city. A further 3000 will be replaced over the remaining 20 years of the contract.

## Benefits

At the end of these works Sheffield will be less vulnerable to flooding and the disruption and harm it causes.

More information can be found at [www.sheffield.gov.uk/streetsahead](http://www.sheffield.gov.uk/streetsahead)



working  
with



## Please help us

Parked cars often prevent us from cleaning gullies. So we aim to give you as much advance notice as possible through temporary signage on the road that will inform you when we need to clean the gullies in your area.

We can get our works completed quicker, if you:

- Pay attention to our signage
- Avoid parking over the gullies
- Find alternative parking if necessary until the cleaning operation has finished

We thank you in advance for your cooperation.

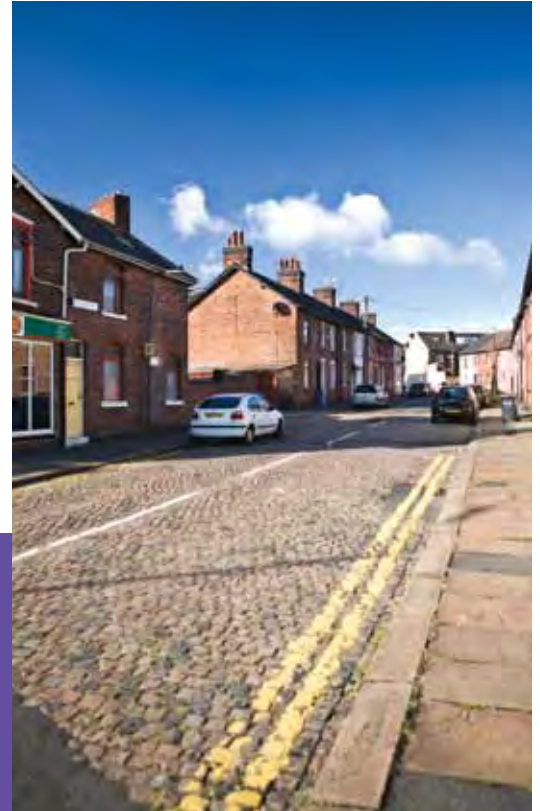

## Did you know?

Our Streets Ahead provider is responsible for maintaining on our behalf:

- over 72,000 highway gullies

**making Sheffield better.**



## Safer, stronger, cleaner bridges coming soon

As part of the Streets Ahead project, we have plans to inspect, repair and strengthen the bridges and other structures that we own across the city. This is to make sure they are safe and functional and can sustain heavy traffic without having to impose weight restrictions, which will allow traffic to flow much more easily in the future.

As part of the Streets Ahead improvements, our Streets Ahead provider, Amey, will be:

- Strengthening 44 bridges
- Repairing stone, concrete and steel bridges
- Repairing retaining walls

- Repainting steel bridges, footbridges and parapet fences
- Removing overgrown and damaging vegetation
- Preventing leaks
- Cleaning and removing rubbish, debris and graffiti

More information can be found at [www.sheffield.gov.uk/streetsahead](http://www.sheffield.gov.uk/streetsahead)



working  
with



## Benefits

At the end of these improvement works Sheffield's bridges and structures will be more durable, able to carry loads without restrictions improving journey routes and allowing traffic to flow more easily; and their appearance will be greatly improved keeping our city attractive.



## Did you know?

Our Streets Ahead provider is responsible for maintaining on our behalf:

- 620 bridges, masonry arches, footbridges, viaducts, culverts, subways and gantries
- 2,450 retaining walls that support the road and pavement

**making Sheffield better.**





# Your guide to new street lighting.

[www.sheffield.gov.uk/streetsahead](http://www.sheffield.gov.uk/streetsahead)



working  
with



# making Sheffield brighter.

68,000 new energy efficient  
LED streetlights.

This document can be supplied  
in alternative formats,  
please contact 0114 273 4567

Sheffield City Council  
Customer Services  
Email: [streetsahead@sheffield.gov.uk](mailto:streetsahead@sheffield.gov.uk)  
[www.sheffield.gov.uk/streetsahead](http://www.sheffield.gov.uk/streetsahead)



# Your guide to tree replacements.

[www.sheffield.gov.uk/streetsahead](http://www.sheffield.gov.uk/streetsahead)



working  
with



# making Sheffield greener.

36,000 healthier trees  
giving you greener streets.

This document can be supplied  
in alternative formats,  
please contact 0114 273 4567

Sheffield City Council  
Customer Services  
Email: [streetsahead@sheffield.gov.uk](mailto:streetsahead@sheffield.gov.uk)  
[www.sheffield.gov.uk/streetsahead](http://www.sheffield.gov.uk/streetsahead)





# Your guide to improved roads and pavements.

[www.sheffield.gov.uk/streetsahead](http://www.sheffield.gov.uk/streetsahead)



working  
with



# making Sheffield safer.

2050 miles of improved pavements  
making it easier underfoot.

This document can be supplied  
in alternative formats,  
please contact 0114 273 4567

Sheffield City Council  
Customer Services  
Email: [streetsahead@sheffield.gov.uk](mailto:streetsahead@sheffield.gov.uk)  
[www.sheffield.gov.uk/streetsahead](http://www.sheffield.gov.uk/streetsahead)



# Your guide to road and pavement upgrades.

[www.sheffield.gov.uk/streetsahead](http://www.sheffield.gov.uk/streetsahead)



# making Sheffield smoother.

1,180 miles of improved roads giving a smoother ride.

This document can be supplied in alternative formats, please contact 0114 273 4567

Sheffield City Council  
Customer Services  
Email: [streetsahead@sheffield.gov.uk](mailto:streetsahead@sheffield.gov.uk)  
[www.sheffield.gov.uk/streetsahead](http://www.sheffield.gov.uk/streetsahead)



# Smother roads and pavements are coming

As part of our Streets Ahead contract we have plans to improve approximately 73% of our city's roads and pavements.

For the first time, every road and pavement in the city will be visually inspected to understand its condition by our Streets Ahead provider Amey who is developing a planned programme of improvement works.

This work is essential to bring the city's highway up to a standard, which will bring benefits beyond improving your daily journeys, it is also vital in supporting the growth and visual appearance of the city.

## In the first five years

2,050 miles of pavements and 1,180 miles of roads will be improved in the first five years known as the 'core investment period' of the 25 year contract.

It is some of the most important work we'll do as part our project but it is also some of the most disruptive. We might need to close your road, or use other traffic management techniques such as temporary traffic lights or introducing single traffic, whilst we complete our improvement works.

We'll inform you by letter before we start any works in your area.

More information can be found at [www.sheffield.gov.uk/streetsahead](http://www.sheffield.gov.uk/streetsahead)



working  
with



## Benefits of smoother roads and pavements

There are many benefits smoother surfaces will bring to you and your community such as:

- a safer environment for all road users, and leading to fewer accidents for drivers, cyclists and pedestrians.
- reduced wear and tear on motor vehicles, reduce fuel consumption and reduce carbon emissions.



## Did you know?

Our Streets Ahead provider is responsible for maintaining on our behalf:

- 1,180 miles of roads – known as the ‘adopted’ highway i.e. those that are maintained at public expense
- 2,050 miles of pavements
- 72,000 highway gullies

And is responsible for providing the following services:

- Maintaining road surfaces and repairing potholes, chipped kerbs and pavements
- Carrying out road markings
- Fixing and maintaining man hole covers

**making Sheffield smoother**  
**1,180 miles of improved roads giving a smoother ride**



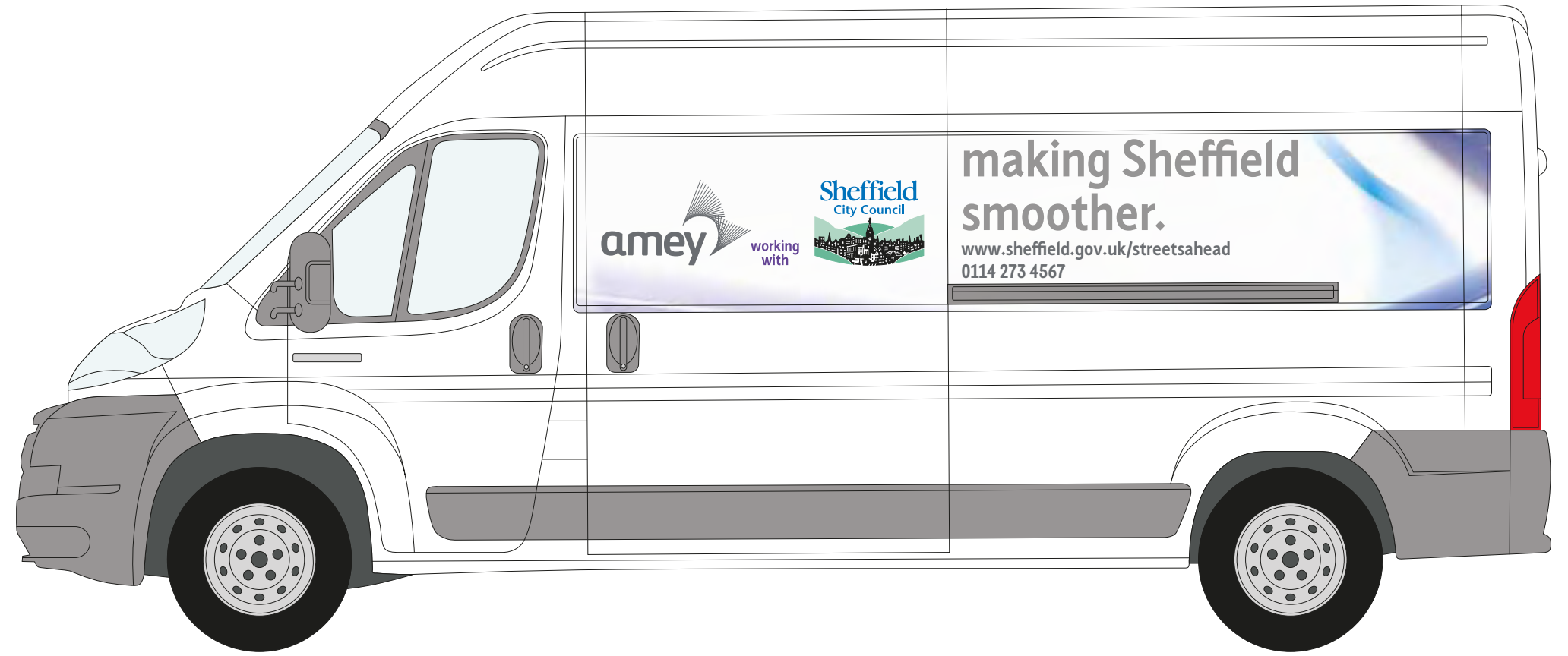
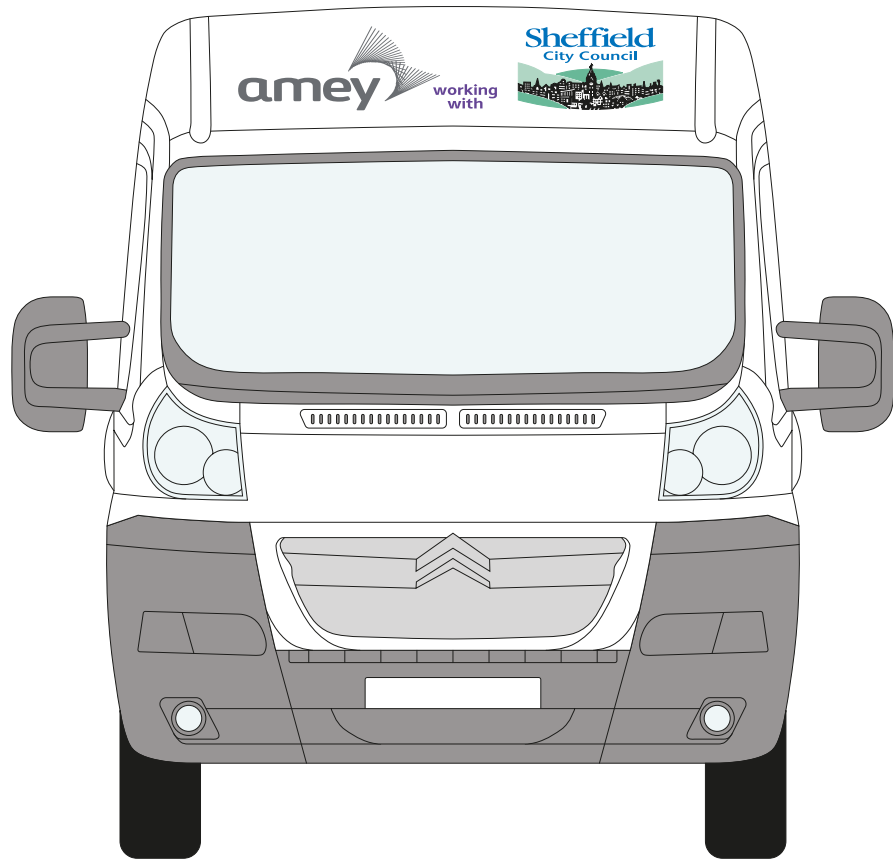



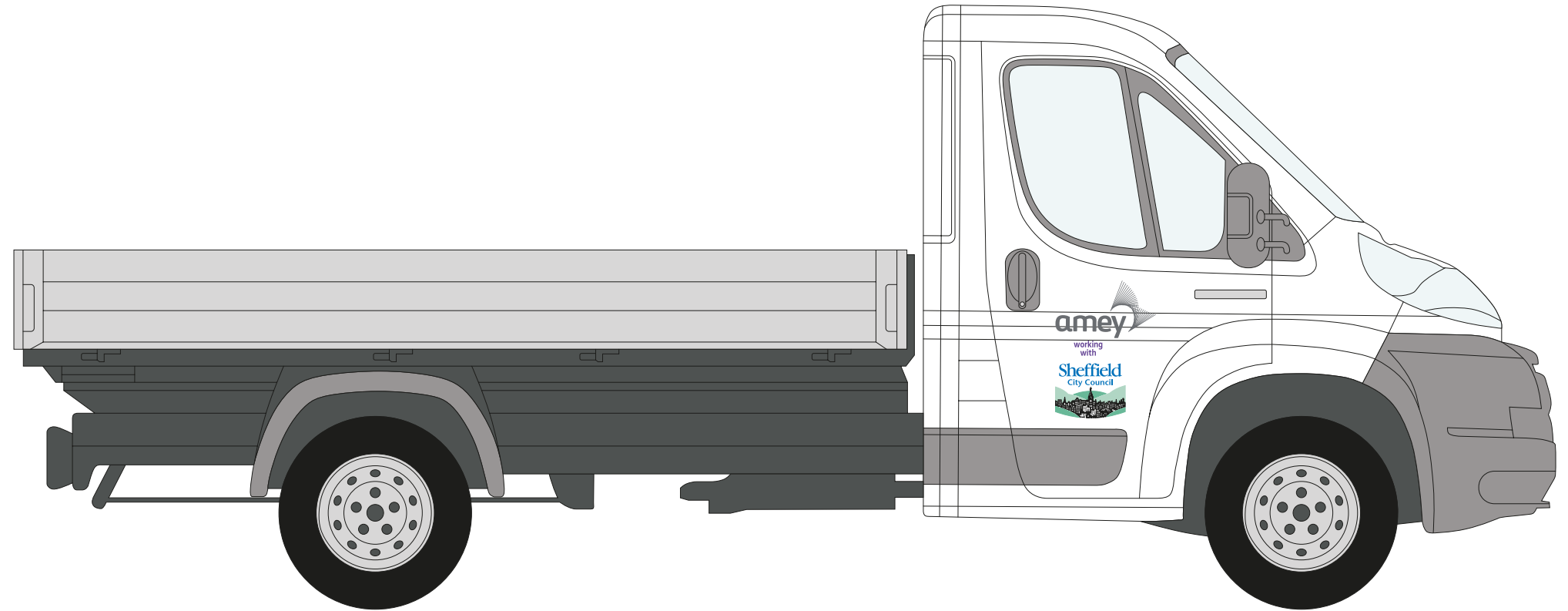
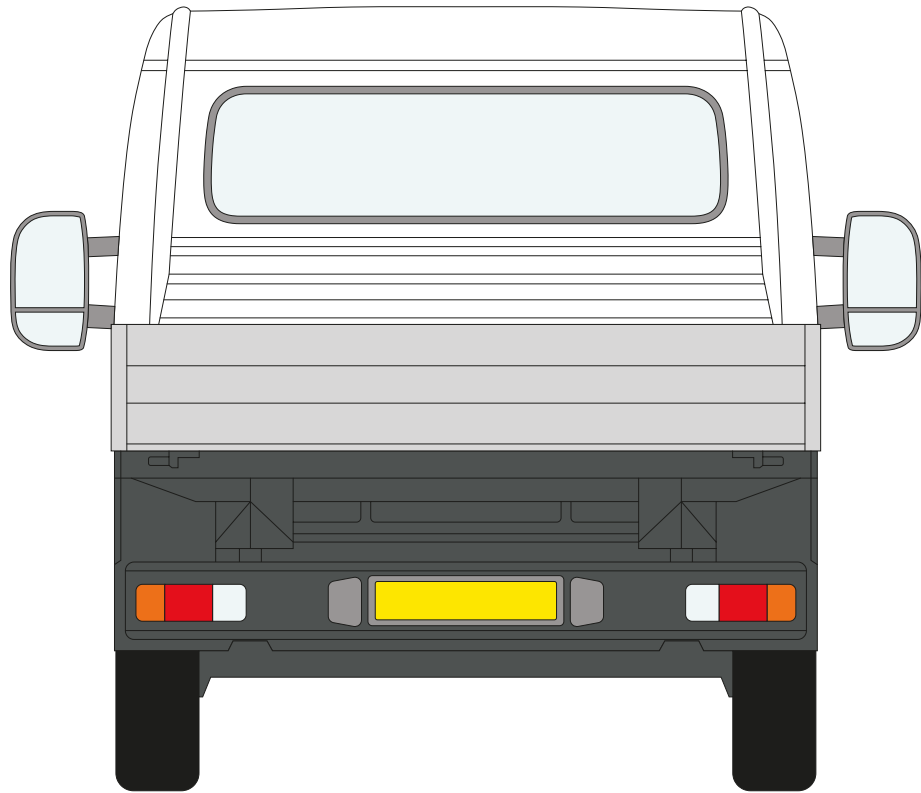
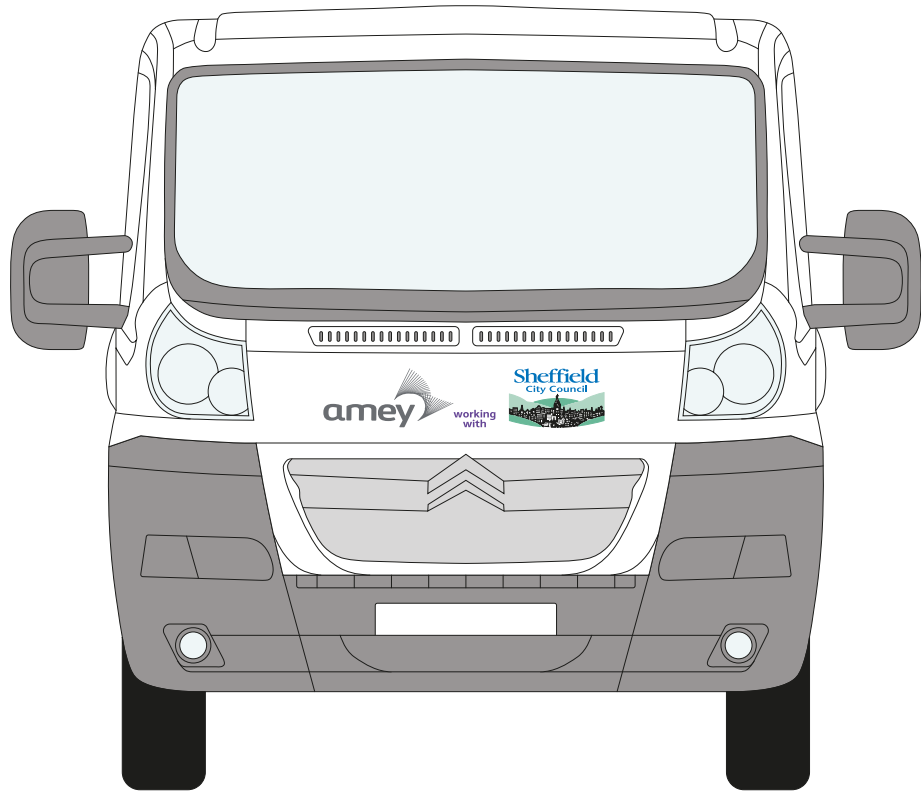

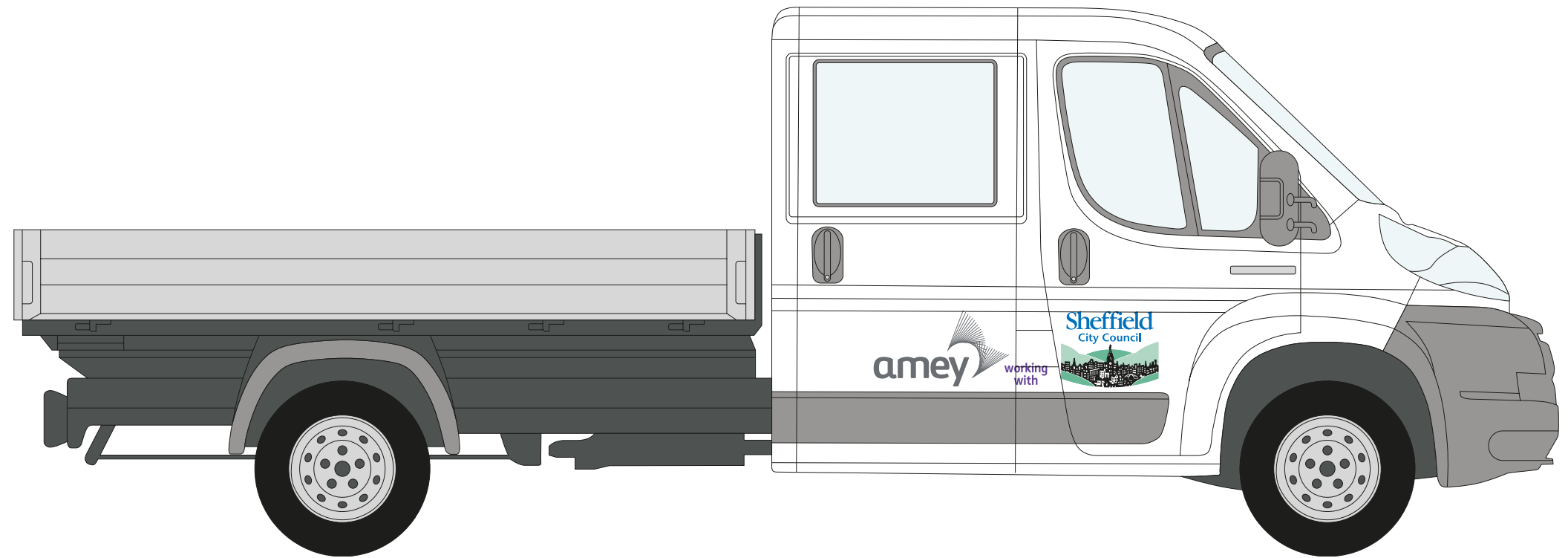
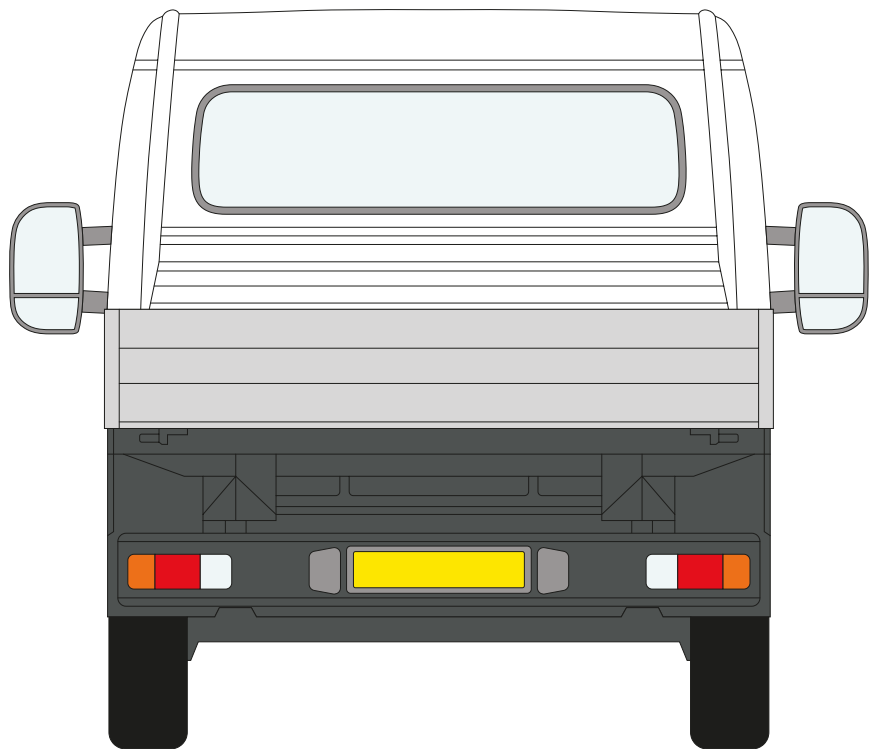
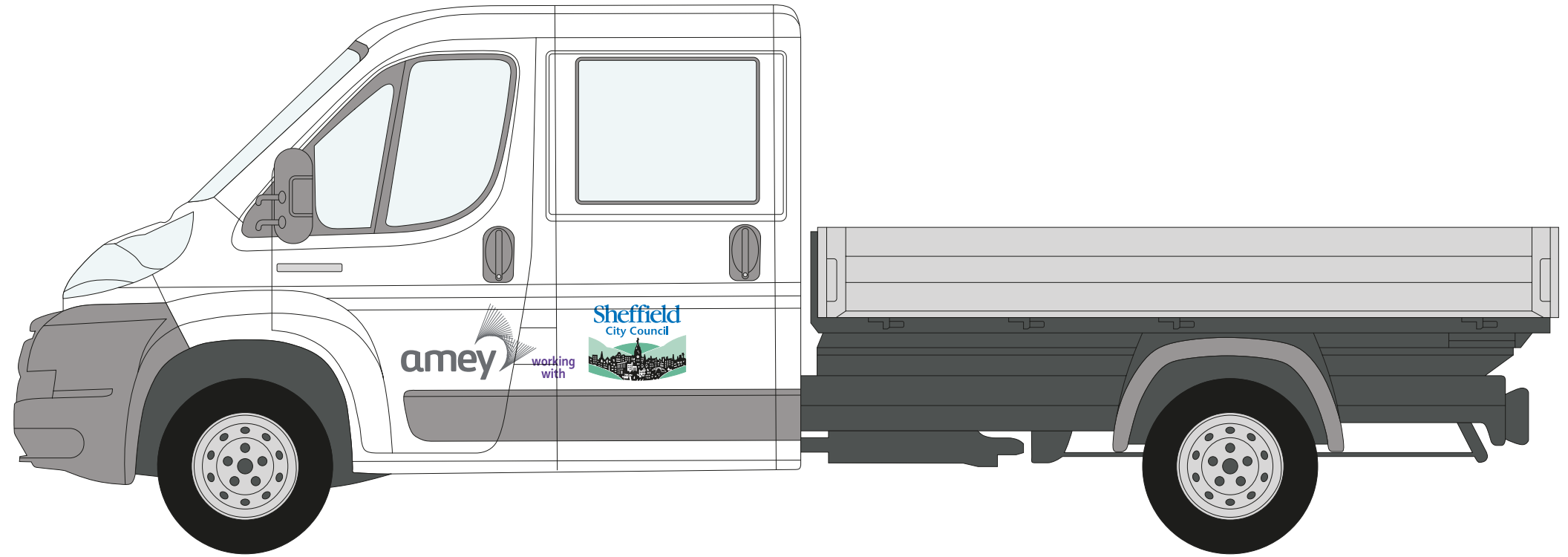
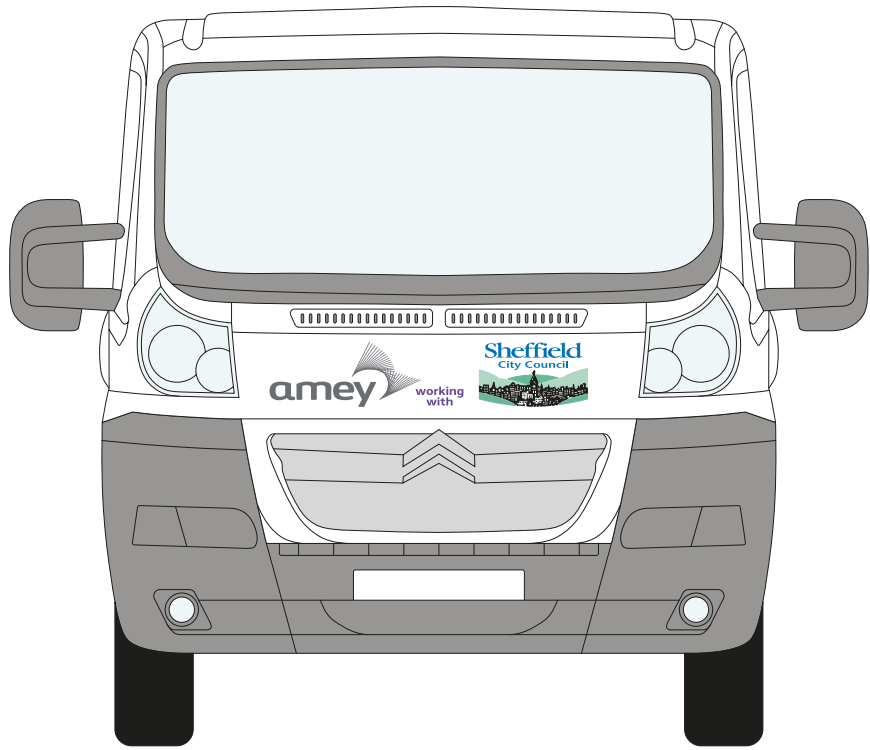



# making Sheffield brighter.

68,000 new energy efficient  
LED streetlights.

[www.sheffield.gov.uk/streetsahead](http://www.sheffield.gov.uk/streetsahead)



working  
with







# making Sheffield brighter.

68,000 new energy efficient  
LED streetlights.

[www.sheffield.gov.uk/streetsahead](http://www.sheffield.gov.uk/streetsahead)



working  
with







# making Sheffield greener.

36,000 healthier trees  
giving you greener streets.

[www.sheffield.gov.uk/streetsahead](http://www.sheffield.gov.uk/streetsahead)



working  
with







# making Sheffield smoother.

1180 miles of improved roads giving a smoother ride.

[www.sheffield.gov.uk/streetsahead](http://www.sheffield.gov.uk/streetsahead)



working with







# making Sheffield safer.

2050 miles of improved pavements making it easier underfoot.

[www.sheffield.gov.uk/streetsahead](http://www.sheffield.gov.uk/streetsahead)



working  
with







# making Sheffield safer.

2050 miles of improved pavements making it easier underfoot.

[www.sheffield.gov.uk/streetsahead](http://www.sheffield.gov.uk/streetsahead)



working  
with





# making Sheffield better.

Report a highway problem  
or get more information on  
Streets Ahead works at:

Telephone: 0114 273 4567

Email: [streetsahead@sheffield.gov.uk](mailto:streetsahead@sheffield.gov.uk)

[www.sheffield.gov.uk/streetsahead](http://www.sheffield.gov.uk/streetsahead)



working  
with





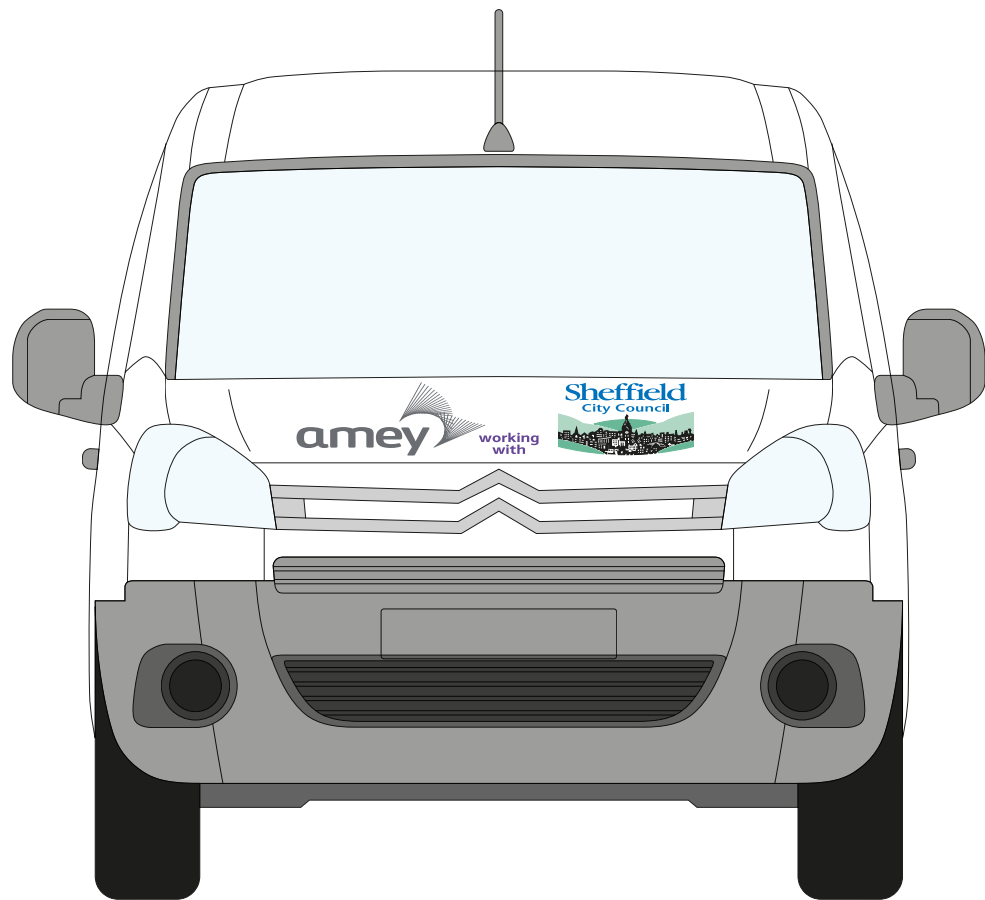

# making Sheffield better.

We're working hard across your city to improve the roads, pavements and streetscene. This forms part of the Streets Ahead works. We aim to do this as quickly and efficiently as possible to minimise disruption to you and your community.

Thank you for your understanding and support during this time.  
If you need to report a problem, or require information,  
please contact us on:

**Telephone: 0114 273 4567**

**Email: [streetsahead@sheffield.gov.uk](mailto:streetsahead@sheffield.gov.uk)**

**[www.sheffield.gov.uk/streetsahead](http://www.sheffield.gov.uk/streetsahead)**



working  
with





**68,000**

**new energy efficient  
LED streetlights.**

**making Sheffield  
brighter.**





# 1,180

miles of improved roads  
giving a smoother ride.

making Sheffield  
smoother.



**2,050**

**miles of improved pavements  
making it easier underfoot.**

**making Sheffield  
safer.**



# 36,000

healthier trees giving  
you greener streets.

making Sheffield  
greener.





# making Sheffield better



working  
with



# making Sheffield better

This is your guide to the Sheffield Streets Ahead works. It explains our plans to improve the city's roads, pavements, street lighting, bridges and streetscene. Inside you will find details about the type of works we're carrying out across the city and the benefits they will bring to you and your community.



# Exciting times ahead

“The long-term benefits the Streets Ahead project will bring to our city are hugely exciting. As one of the largest investment projects in Sheffield’s history, the contract finally provides us with a once in a lifetime opportunity to improve the condition of the city’s highway network for the benefit of all who use it.

“I know Sheffielders have been calling for these highways improvements to be carried out for a long time and as a result it’s always been a priority for us to secure the investment needed to bring our highways infrastructure up to standard.

“I’m pleased that having successfully secured £2 billion of investment we have appointed our private contractor, Amey, to deliver the Streets Ahead contract on our behalf. Everything is now in place for Sheffield highways to be transformed. And I for one am extremely excited.

“We can all now look forward to; smoother roads and pavements surfaces, a brighter, well-lit and safer streetscene that is also more attractive, clearly signed streets for easier travel as well as benefitting from a better designed highway network fit for the future.”

Julie Dore,  
Council Leader at  
Sheffield City Council

**making Sheffield  
brighter.**

68,000 new energy efficient  
LED streetlights.

**making Sheffield  
greener.**

36,000 healthier trees  
giving you greener streets.

**making Sheffield  
smoother.**

1,180 miles of improved roads  
giving a smoother ride.

**making Sheffield  
safer.**

2,050 miles of improved pavements  
making it easier underfoot.



# The Streets Ahead Project

The Streets Ahead project is a huge city-wide project that will improve the condition of our city's roads, pavements, street lighting, bridges and streetscene within the first five years of a 25 year contract. These highway assets are then maintained at that improved standard for the remaining 20 years of the contract.

## Introducing the Streets Ahead provider

Our Streets Ahead provider is private sector public service provider, Amey. We selected Amey to deliver our Streets Ahead project in April 2012.

Amey is now responsible for delivering the Streets Ahead works across the city on our behalf.

We'll be working together over the next 25 years to make sure that the city's highway network is fit for the future.

Amey is now ultimately responsible for repairing and maintaining our city's highway network and its assets which includes:

1. 36,000 trees
2. 12,700 street nameplates
3. 28,000 street signs, illuminated and non-illuminated
4. 68,000 streetlights
5. 2,050 miles of pavement
6. 480 traffic signals
7. 1,181 miles of road
8. 2,000 grit bins
9. 18,000 items of street furniture
10. 3 million sqm of grass verges
11. 2,500 litter bins
12. 72,000 drainage gullies
13. 600 bridges and other structures



**Maintenance of these assets will be carried out by our Streets Ahead provider Amey for a further 20 years**

# Major improvements in five years (2012 – 2017)

The first five years of the Streets Ahead contract is known as the 'core investment period'. It is an intense period of time that will see 73% of our city's highway network upgraded and enhanced. It is the time when Streets Ahead will be carrying out the majority of work.

Within the first five years of the contract between 2012 and 2017, Streets Ahead will:

- Resurface 2,050 miles of pavement and 1,180 miles of road
- Upgrade more than 58,000 street lighting columns and lamps with energy efficient LED technology
- Strengthen 44 bridges
- Replace 25% of our traffic lights and signals
- Install 3,000 new highway gullies
- Install 1,000 new litter and recycling bins
- Carry out 126 drainage improvement schemes
- Replace 5,000 trees







## Planning to minimise disruption

We've been working closely with our Streets Ahead provider Amey to plan an efficient and cost-effective programme to limit the impact of the Streets Ahead works on people living, working or visiting the city. Together we've devised a 'zonal approach' to carry out these works.

# Our 'zonal approach'

Over the course of the five years 'core investment period' between 2012-2017, we will be upgrading the city's roads, pavements, street lighting, bridges and streetscene in a sequenced and zonal approach. The zonal approach divides the city into zones to reduce the impact of these works and keep the city moving.



There are 108 zonal schemes to be completed within the first 5 years of the 25 year contract. The zones have been divided as follows:

- A zones – these represent works happening on main arterial routes across the city. There are 27 A zones across the city.
- B zones – these represent works happening on local and less busy roads normally within community or residential areas. There are 81 B zones across the city.

Each zone is unique, requiring different types and levels of work. For example it could be one of more of the following:

- Tree replacement and maintenance
- Street lighting column and lamp upgrades
- Bridge and other structure repairs and improvements
- Gullies and drainage improvements
- Traffic light and signal repairs and improvements

Each zone will take approximately 15 weeks to complete, depending on the work required.

To carry out these essential works safely, we will need to use traffic management temporary traffic lights, single lane traffic, roads closures and diversions across the city. But we aim to keep this disruption to a minimum.

This work will take place using a sequenced approach with each task being undertaken by a specialist team. By concentrating the improvements needed in a short intensive period (approximately 15 weeks), Streets Ahead hope to complete all major works in one go and should not need to return in the near future.

We have planned these works to take place during off peak hours, where possible, to minimise inconvenience for the majority of residents and businesses. Temporary warning signs will be displayed in each zone confirming the start date and expected duration of the work in advance. If it is necessary to change these arrangements (for instance in the event of severe weather) the warning signs will be updated accordingly.

The latest information about works in your area can be found at: [www.sheffield.gov.uk/streetsahead](http://www.sheffield.gov.uk/streetsahead)





## Please bear with us

We know that roadworks and any level of disruption can be frustrating, but we'll be keeping those of you directly affected informed.

We apologise in advance, but we think the long-term benefits of the Streets Ahead works will

outweigh the short term inconvenience. We hope you will too.

We appreciate your patience and support whilst work is being carried out on your street or in your area.



## Call for caution and cooperation

During our improvement works we ask that you allow extra time for your journeys, particularly at peak times, and pay close attention to all traffic and advanced warning signs.

Motorists and cyclists should also be aware that there will be operatives and construction vehicles on the highway whilst work is taking

place, and in the interest of keeping all road users and our workforce safe, we would appreciate your cooperation in driving safely through any roadworks.

**Thank you**

# Get there sooner

You might want to visit [gettheresooner.travelsouthyorkshire.com](http://gettheresooner.travelsouthyorkshire.com) which can help you plan your journey to avoid the roadworks or consider public transport options.

## Keeping you informed

Check our webpages at:

[www.sheffield.gov.uk/streetsahead](http://www.sheffield.gov.uk/streetsahead)

These pages will provide you with detailed information on when and where work will be taking place, roadworks, and advice to help you plan your journey.

## Attend a roadshow

You'll be invited to attend a roadshow to find out when works will start in your area, the level of impact on you and your community and ask any questions.

Details of dates, times and locations will be publicised on our webpages [www.sheffield.gov.uk/streetsahead](http://www.sheffield.gov.uk/streetsahead) and by posters in the local area – so keep an eye out.

## Letter drops

Residents or businesses that are directly affected by the works will receive a letter through the post, detailing the nature of the works happening on your road or street before any planned works start.







### **Get involved with your Community Assembly**

Community assemblies hold regular public meetings in your area that anyone can attend.

At these meetings, there will be updates from our Streets Ahead team on the progress of the project and works in your area and how they have been responding to communities' views and feedback.

For meeting dates, times and locations please visit our website at [www.sheffield.gov.uk/communityassemblies](http://www.sheffield.gov.uk/communityassemblies)

# Your Assembly Steward

These are dedicated people within your local community assembly area who work for our Streets Ahead provider, Amey. They are knowledgeable about the project and armed with technical expertise. Your Assembly Steward can explain the plan for works in your local area to you.

You can request a meeting with your local assembly steward by contacting us:

Sheffield City Council Customer First Service  
Howden House, Union Street, Sheffield, S1 2HH  
Telephone: 0114 273 4567  
Email: [firstpoint@sheffield.gov.uk](mailto:firstpoint@sheffield.gov.uk)

## Sign up for Customer First email alerts

We can keep you informed with progress on these works and other Streets Ahead news by emails. Sign up now via our dedicated webpages at [www.sheffield.gov.uk/streetsahead](http://www.sheffield.gov.uk/streetsahead)

## Follow us on twitter

We'll be tweeting updates throughout the lifetime of the project so follow us @sheffieldcouncil

## Check our Facebook pages

We'll be posting updates on our Facebook pages find us - Sheffield City Council.



# Feel the benefits

This is a once in a life-time opportunity to upgrade the city's highway network for the benefit of all who use it.

Although it will take Streets Ahead five years to complete all of the planned improvements works, almost immediately you should start to see and feel the main benefits from:

## making Sheffield smoother

- Smoother road surfaces which will reduce wear and tear on motor vehicles, reduce fuel consumption and reduce carbon emissions

## making Sheffield brighter

- Replacing street lighting, traffic lights and illuminated signs with new energy saving LED technology, significantly reducing energy consumption
- Improved quality of light which will help to reduce crime and fear of crime

## making Sheffield safer

- Smoother road and pavement surfaces, complemented by clear signage and markings, providing a safer environment for all road users, and leading to fewer accidents for drivers, cyclists and pedestrians

## making Sheffield greener

- Improved road and pavement surfaces and lighting will encourage more people to adopt environmentally friendly and healthier forms of transport, including walking and cycling
- Maintaining 36,000 healthier highways trees to keep our city green





Sheffield City Council Customer Services  
Howden House, Union Street, Sheffield, S1 2HH

Telephone: 0114 273 4567

Email: [streetsahead@sheffield.gov.uk](mailto:streetsahead@sheffield.gov.uk)

Web: [www.sheffield.gov.uk/streetsahead](http://www.sheffield.gov.uk/streetsahead)



# Streets Ahead is coming to Shiregreen.

Come to our roadshow to find out more about the highway improvements works soon to be carried out in your area.

**When:** 25 July 2012

**Time:** 4pm-8pm (drop in anytime)

**Where:** Shiregreen Neighbourhood Centre,  
Westnall Road, S5 0AA

## You'll learn:

- Details about the types of works planned in your area
- Timescales for these works to be carried out
- The long-term benefits this bring to you and your community

**We hope to see you there.**

**making Sheffield better.**



working  
with







# Streets Ahead is coming to Ewden.

Come to our roadshow to find out more about the highway improvements works soon to be carried out in your area.

**When:** 1 August 2012

**Time:** 5pm-8pm

**Where:** Bolsterstone Village Hall, S36 3ZH

## You'll learn:

- Details about the types of works planned in your area
- Timescales for these works to be carried out
- The long-term benefits this bring to you and your community

**We hope to see you there.**

**making Sheffield better.**





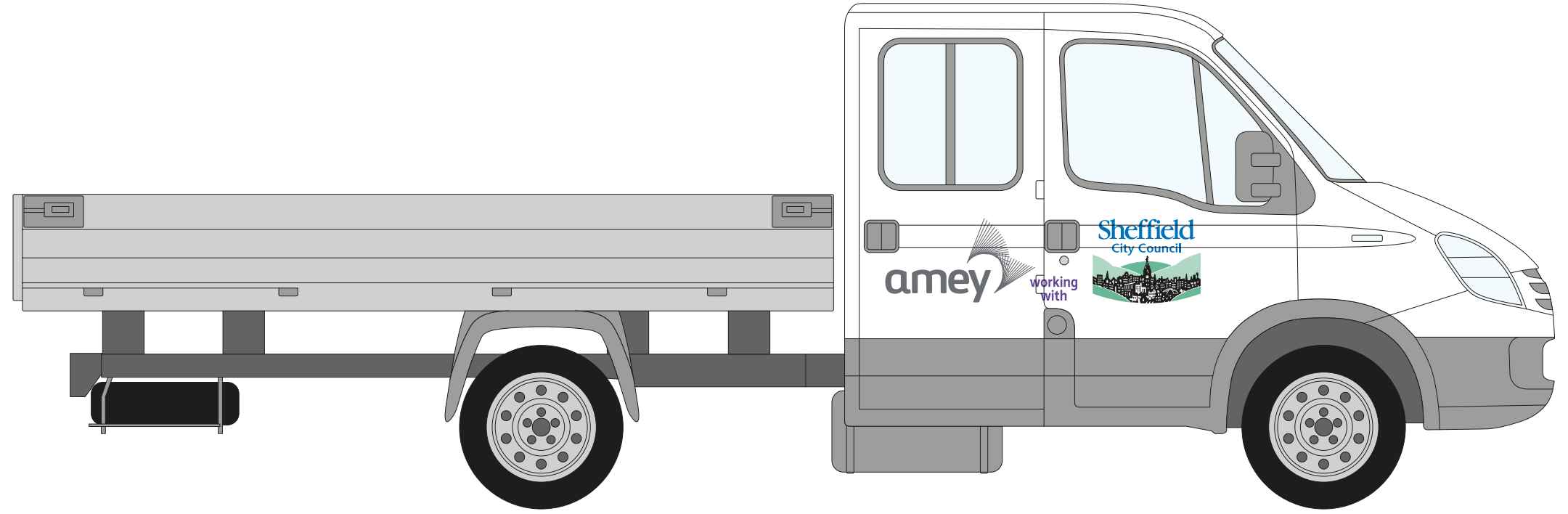
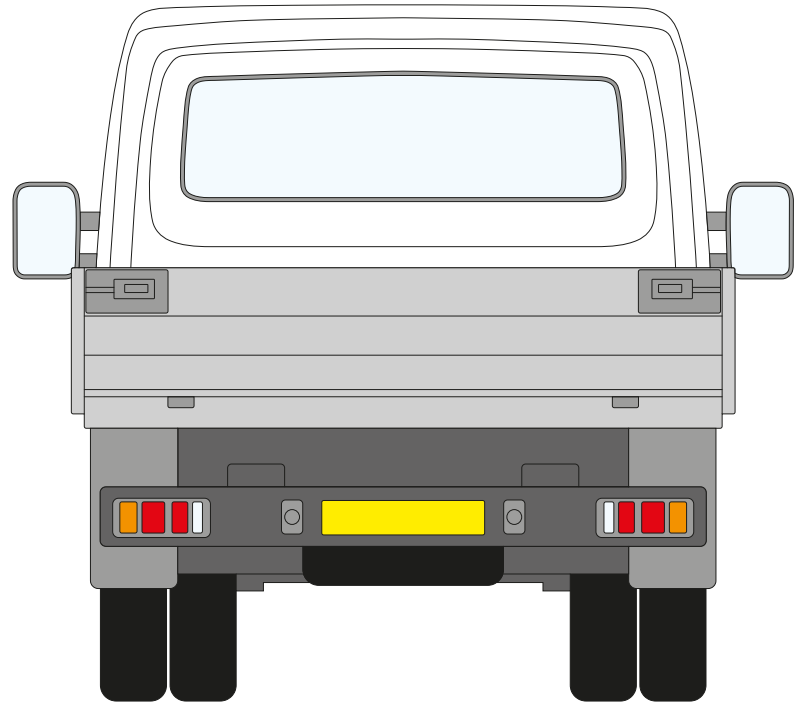
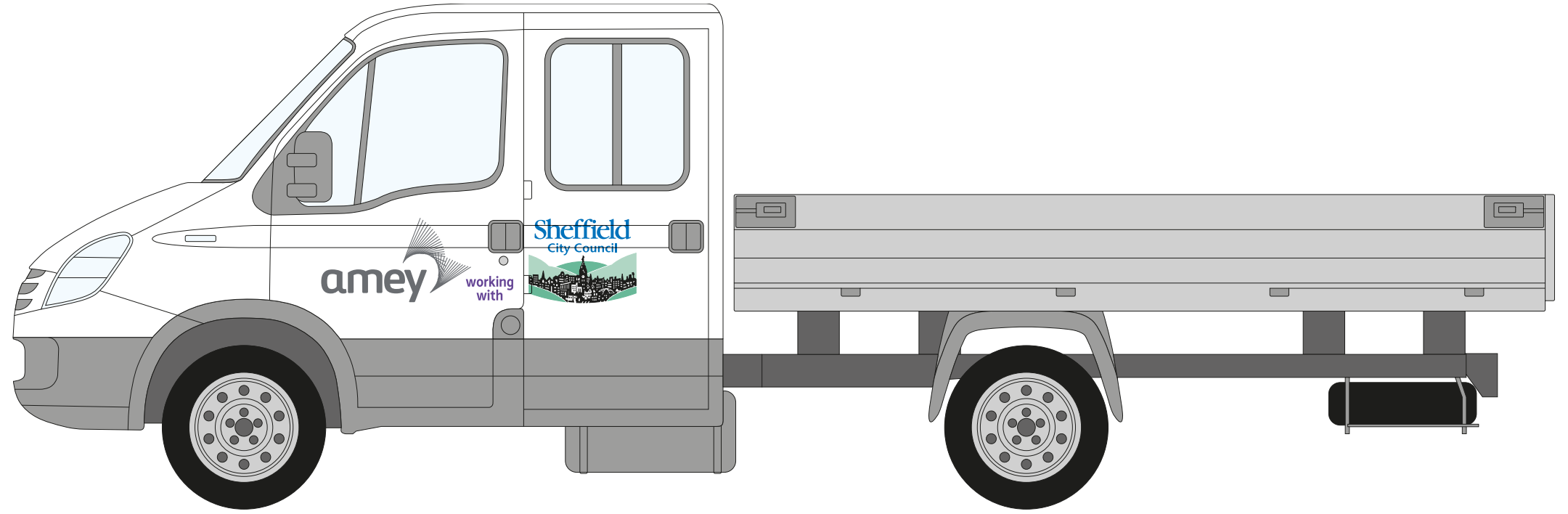
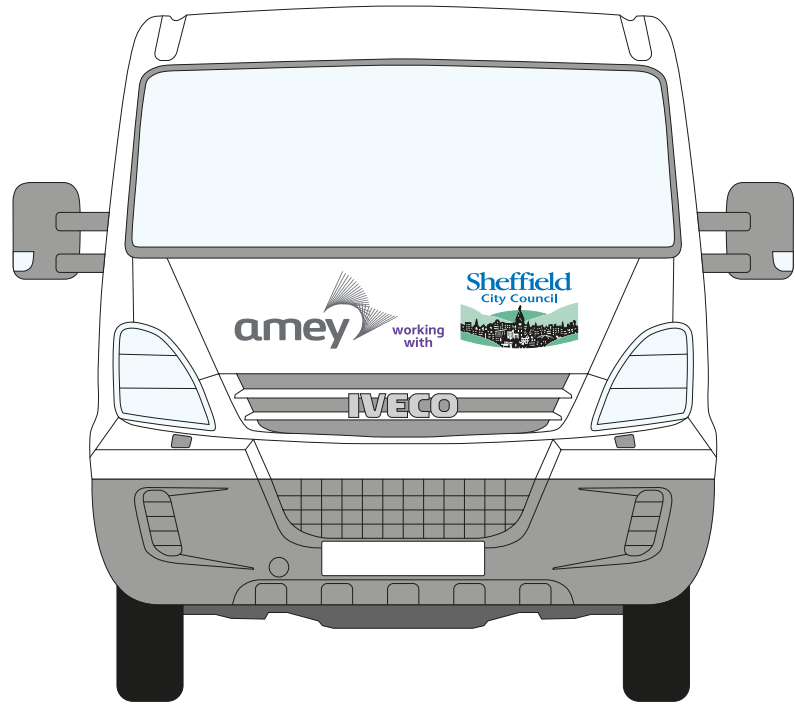

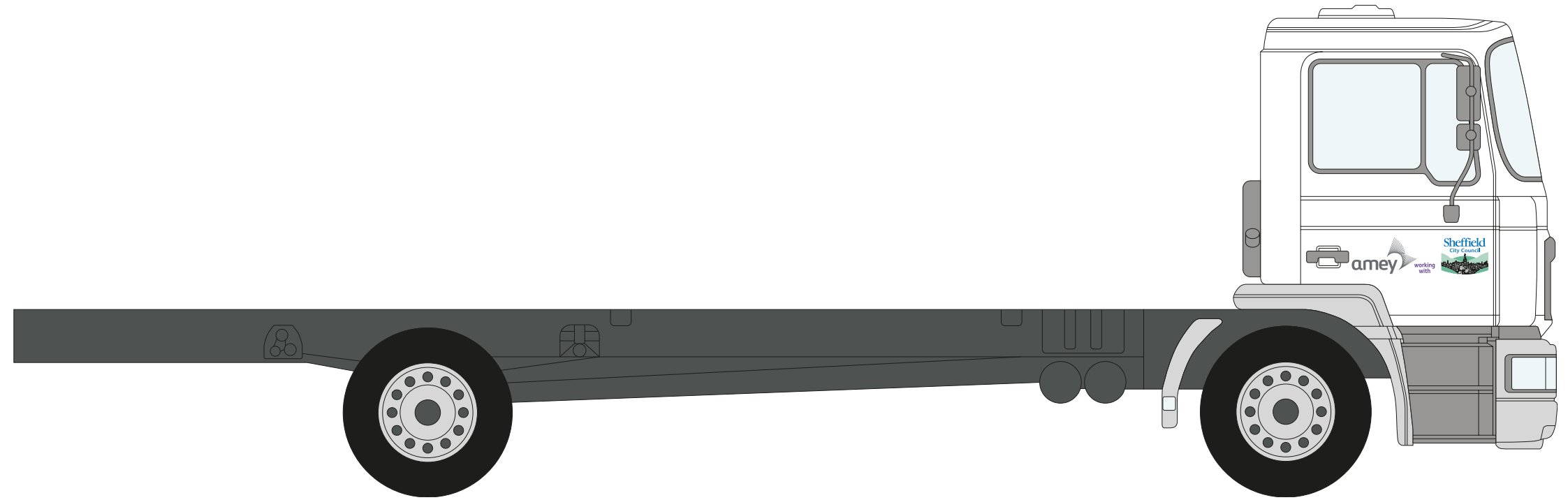
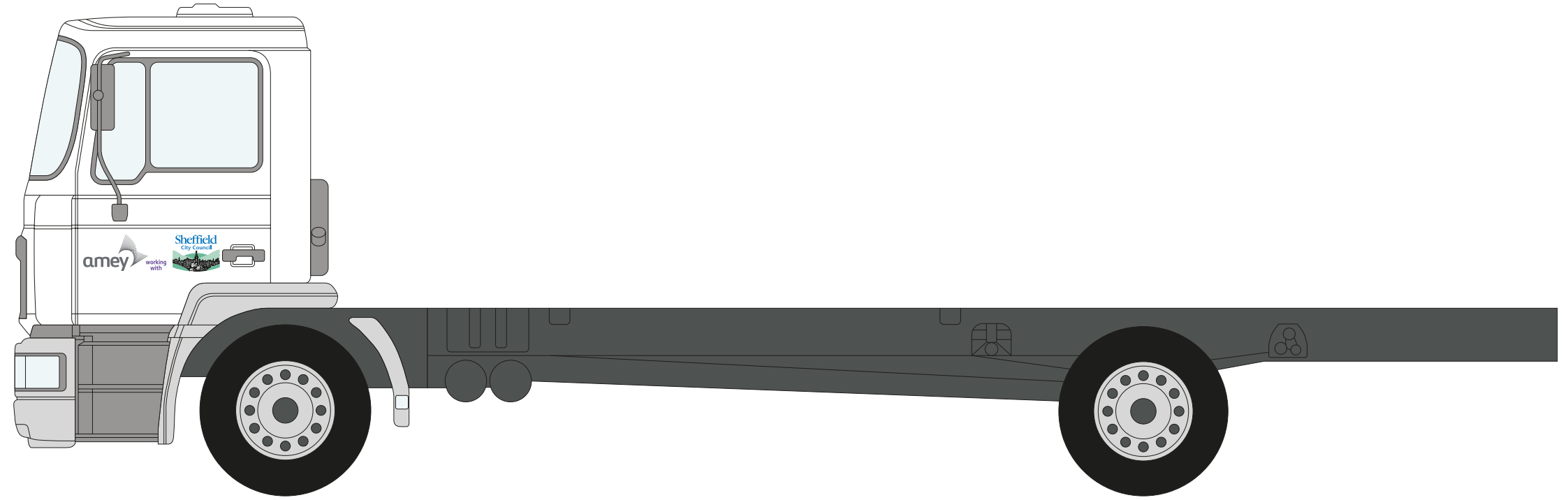

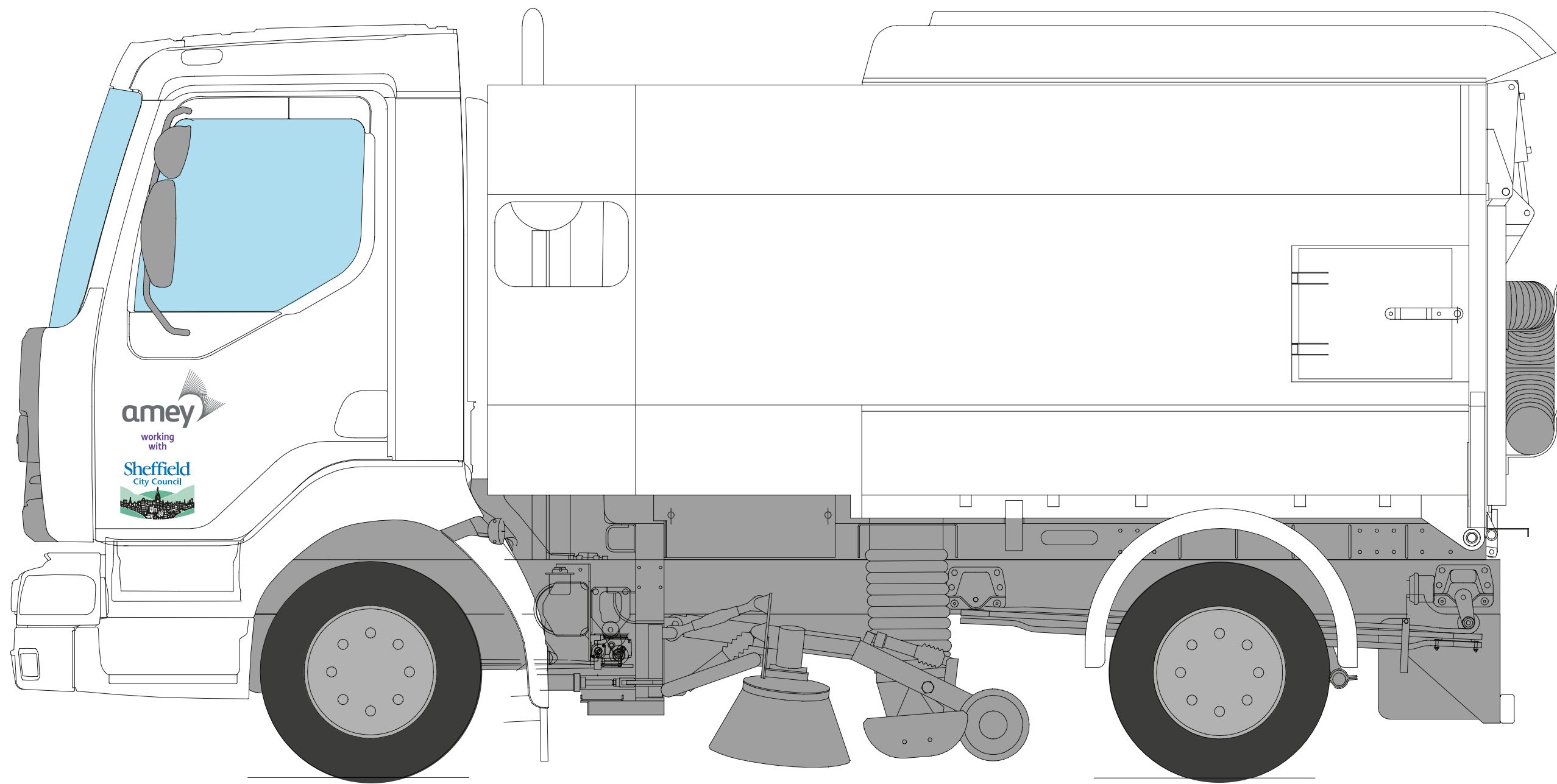



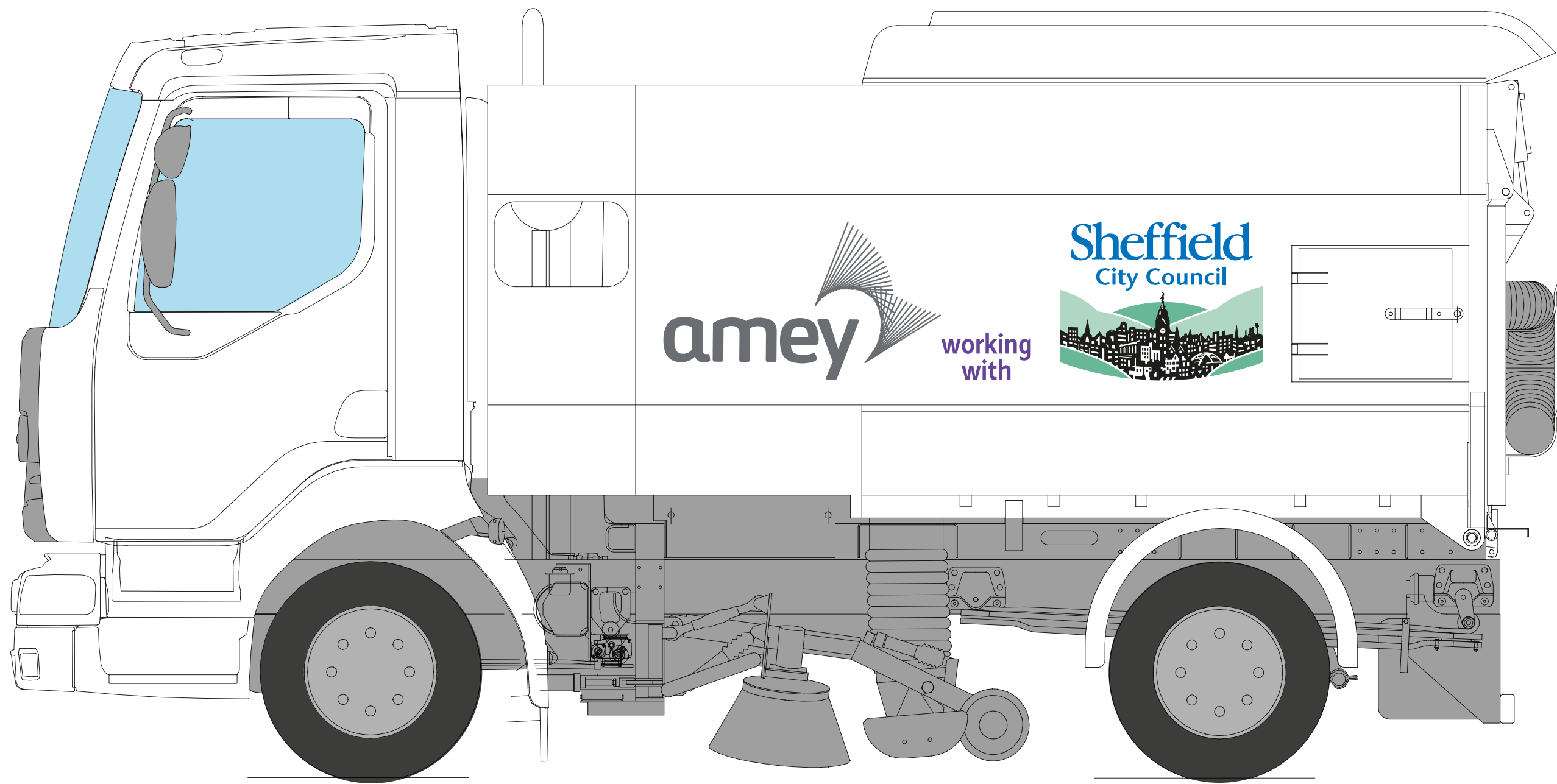

amey

working with

Sheffield  
City Council

